



Verband der
Automobilindustrie

5

Quality Management in the Automotive Industry

Capability of Measurement Processes

Capability of Measuring Systems
Capability of Measurement Processes
Expanded Measurement Uncertainty
Conformity Assessment

2nd completely revised edition 2010, updated July 2011

Dokument wurde bereitgestellt vom
VDA-QMC Internetportal am 18.08.2011 um 01:03

Nur zur internen Verwendung für VDA QMC China (Beijing) Co.,Ltd. bestimmt.

Capability of Measurement Processes

Capability of Measuring Systems
Capability of Measurement Processes
Expanded Measurement Uncertainty
Conformity Assessment

Second completely revised edition 2010, up-dated July 2011

Verband der Automobilindustrie e.V. (VDA)

ISSN 0943-9412

Printed: 07/2011

**This version corresponds to the modified
German version of July 2011**

A change data sheet VDA 5 / 2011 versus VDA 5 / 2010,
can be downloaded, access see page 166

Copyright 2011 by

Verband der Automobilindustrie e.V. (VDA)
Qualitäts Management Center (QMC)
10117 Berlin, Behrenstraße 35
Germany

Overall production:
Henrich Druck und Medien GmbH
60528 Frankfurt am Main, Schwanheimer Straße 110
Germany

Printed on chlorine-free bleached paper

Noncommittal VDA recommendation regarding standards

The German Association of the Automotive Industry (Verband der Automobilindustrie e.V. - VDA) advises its members to apply the following recommendation regarding standards in implementing and maintaining QM systems.

Exclusion of liability

VDA Volume 5 is a recommendation that is free for anyone to use. Anyone using it has to ensure that it is applied correctly in each individual case.

VDA Volume 5 considers the latest state of the art at the date of publication. The application of the VDA recommendation does not absolve users from their personal responsibility for their own actions. Users are acting at their own risk. The VDA and anyone involved in providing this VDA recommendation exclude liability for any damage.

Anyone using this VDA recommendation is asked to inform the VDA in case of detecting any incorrect or ambiguous information in order that the VDA can fix possible errors.

References to standards

The individual standards referred to by their DIN standard designation and their date of issue are quoted with the permission of the DIN (German Institute for Standardization). It is essential to use the latest issue of the standards, which are available at Beuth Verlag GmbH, 10772 Berlin, Germany.

Copyright

This document is protected by copyright. Any use outside the strict limits stipulated by copyright law is prohibited without the consent of the VDA and is punishable by law. This applies particularly with regard to copying, translating, microfilming, storing and processing the document in electronic systems.

Translations

This document will also be translated into other languages. Please contact the VDA-QMC for information about the latest translations.

Preface

Different standards and guidelines contain requirements for estimating and considering the measurement uncertainty. In this regard, companies have to face various questions in implementing and certifying their quality management system.

This document explains how to meet these various requirements. A work group of the automotive and supplier industry created VDA Volume 5. It applies to all parts of this branch of industry.

The procedures described in this document are based on the ISO/IEC Guide 98-3 (Guide to the expression of uncertainty in measurement) (GUM) [22] and on ISO/TS 14253 (Inspection by measurement of work pieces and measuring equipment, Part 1: Decision rules for proving conformance or non-conformance with specifications) [13].

VDA Volume 5 also contains the well-established and widely used procedures of the MSA manual [1] that are used in order to evaluate and accept measuring equipment. It provides some information about the validation of measurement software as well.

In order to ensure the functionality of technical systems, single parts and assemblies have to keep specified tolerances. The following aspects must be considered when determining the necessary tolerances in the construction process:

- The functionality of the product must be ensured.
- Single parts and assemblies must be produced in a way that they can be assembled easily.
- For economic reasons, the tolerances should be as wide as possible, but for functionality reasons, it should be as narrow as necessary.
- The expanded measurement uncertainty must be considered in statistical tolerancing.

Due to the measurement uncertainty, the range around the specification limits does not allow for a reliable statement about conformance or non-conformance with specified tolerances. This might lead to an incorrect evaluation of measurement results. For this reason, it is important to consider the uncertainty of the measuring system and the measurement process as early as in the planning phase.

VDA Volume 5 primarily refers to the inspection of geometrical quantities. Whether or not the approach explained in this document is suitable for measuring physical quantities must be checked in each individual case.

Our thanks go to the following companies and, in particular, to the people involved for their commitment in creating this document:

BMW Group, Munich

Daimler AG, Untertürkheim

Daimler AG, Sindelfingen

GKN Driveline Offenbach

KFMtec Methodenentwicklung, Stuttgart

MAN Nutzfahrzeuge Aktiengesellschaft, Munich

MQS Consulting, Oberhaid

Q-DAS GmbH & Co. KG, Weinheim

Robert Bosch GmbH, Stuttgart

Volkswagen AG, Wolfsburg

Volkswagen AG, Kassel

VW Nutzfahrzeuge, Hanover

We also would like to thank everyone who provided their suggestions and helped us to improve this document.

Berlin, September 2010

Berlin, July 2011

Verband der Automobilindustrie e. V. (VDA)

Table of Contents		Page
Preface		5
1	Standards and Guidelines	10
2	Benefits and Field of Application	11
3	Terms and Definitions	13
3.1	General Terms and Definitions	13
3.2	Proof of Conformance or Non-conformance with Tolerances according to ISO/TS 14253 [13]	22
4	General Procedure for Establishing the Capability of Measurement Processes	26
4.1	Influences Causing the Uncertainty of Measurement Results	26
4.2	General Information	29
4.3	Specific Approaches	30
4.3.1	Measurement Errors	30
4.3.2	Long-term Analysis of Measurement Process Capability	32
4.3.3	Reproducibility of Identical Measuring Systems	32
4.4	Standard Uncertainties	33
4.4.1	Type A Evaluation (Standard Deviation)	34
4.4.2	Type A Evaluation (ANOVA)	34
4.4.3	Type B Evaluation	36
4.4.3.1	Type B Evaluation: Expanded Measurement Uncertainty U_{MP} Known	37
4.4.3.2	Type B Evaluation: Expanded Measurement Uncertainty UMP Unknown	37
4.5	Combined Standard Uncertainty	38
4.6	Expanded Measurement Uncertainty	38
4.7	Calculation of Capability Ratios	40
4.8	Minimum Possible Tolerance for Measuring Systems / Measurement Processes	44
4.9	Uncertainty Budget	45
4.10	Capability of the Measurement and Production Processes	46

4.1.1	Dealing with Not Capable Measuring Systems / Measurement Processes	47
5	Measurement Process Capability Analysis	49
5.1	Basic Principles	49
5.2	Capability Analysis of a Measuring System	50
5.2.1	Resolution of the Measuring System	53
5.2.2	Repeatability, Systematic Measurement Error, Linearity	53
5.2.2.1	Estimating the Systematic Measurement Error and Repeatability according to the "Type 1 Study"	54
5.2.2.2	Linearity Analysis with Correction on the Measuring Instrument	60
5.3	Measurement Process Capability Analysis	64
5.3.1	Example for Determining the Uncertainty Components of the Measurement Process	69
6	Ongoing Review of the Measurement Process Capability	71
6.1	General Review of the Measurement Stability	71
6.2	Correcting the Regression Function	72
7	Practical Guidance to Determining Typical Standard Uncertainties	74
7.1	Overview of Typical Measurement Process Models	79
8	Special Measurement Processes	81
8.1	Measurement Process with Small Tolerances	81
8.2	Classification	81
8.3	Validation of Measurement Software	82
9	Capability Analysis of Attribute Measurement Processes	85
9.1	Introduction	85
9.2	Capability Calculations without Using Reference Values	86
9.3	Capability Calculations Using Reference Values	88
9.3.1	Calculation of the Uncertainty Range	88
9.3.2	Ongoing Review	92
10	Appendix	93

Annex A	Statistical Background of the Measurement Process Capability Analysis	93
Annex B	Estimation of Standard Uncertainties from Temperature	98
Annex C	Reducing the Measurement Uncertainty by Repeating and Averaging Measurements	105
Annex D	<i>k</i> Factors	107
Annex E	Setting Working Point(s)	108
Annex F	Calculation Examples	110
11	Index of Formula Symbols	154
12	Bibliography	158
13	Index	163
14	Downloads	166

1 Standards and Guidelines

Relevant quality management standards and guidelines require knowledge of the measurement uncertainty or a capability analysis of the measuring and test equipment (qualification of the measuring and test equipment for the respective measurement process). The documents listed in Table 1 contain requirements for measurement processes.

Aim	International/national standards and documents	Industry standards
Implementation of QM systems	<ul style="list-style-type: none"> • DIN EN ISO 9000ff [10][11]; • ISO 10012 [12]; • EN ISO/IEC 17025 [19]; • ISO/TS 16949 [23] 	<ul style="list-style-type: none"> • VDA Volume 6, Part 1[26]
Estimation of the measurement uncertainty	<p><i>Metrology, general:</i></p> <ul style="list-style-type: none"> • DIN 1319 [5][6][7]; • ISO/IEC Guide 98-3 (GUM) [22] <p><i>Dimension measurement:</i></p> <ul style="list-style-type: none"> • attachment 1 to ISO 14253-1 [14] 	<ul style="list-style-type: none"> • standards of technical associations • DKD-3 [2]
Calculation of the capability of measuring instruments and measuring equipment	<ul style="list-style-type: none"> • DIN 55319-3 [8] • ISO/WD 22514-7 [24] 	<ul style="list-style-type: none"> • QS-9000/ MSA [1] • corporate standard
Consideration of the measurement uncertainty	<ul style="list-style-type: none"> • ISO/TS 14253-1 [13] 	<ul style="list-style-type: none"> • QS-9000/ MSA [1] • corporate standards

Table 1: Aims specified in certain standards, recommendations and guidelines to the evaluation of measuring equipment

The aim of VDA Volume 5 is to summarize the requirements and procedures of the existing standards and guidelines in order to gain a standardized and practice-oriented model for the estimation and consideration of the expanded measurement uncertainty. The methods and capability analysis (see MSA [1]) established in practice may be integrated where applicable. Table 14 provides answers to typical questions regarding the estimation of standard measurement uncertainties and the expanded measurement uncertainty.

2 Benefits and Field of Application

Measuring systems and measurement processes require an adequate and comprehensive evaluation. This evaluation has to include the consideration of influencing quantities such as the calibration uncertainty on the reference standards and its traceability to a national or an international measurement standard, the influence of the test part or the long-term stability of a measuring instrument in the measurement process.

If the capability of a measurement process is not established, measurement processes that are “not capable“ might be released. This could cause high consequential costs for corrective action and for the on-going review of a production process using SPC. Moreover, an inspection of the measuring systems could lead to discussions and additional, more complex inspections.

The benefits from a qualified measurement process are great, because reliable and correct measurement results form the basis of important decisions, such as whether

- to release or not to release a manufacturing device or measuring equipment.
- to take or not to take corrective action in a running production process.
- to accept or to reject a product.
- to deliver, to rework or to scrap a product.

Furthermore, in the case of product liability, it is required to give proof of the capability of the measurement processes used in order to manufacture and release the product. If this proof cannot be provided, the measurement results, that the evaluation of the products is based on, will always be contested.

In the end, it is important to know that the expression of the measurement uncertainty is not a negative criterion or a deficit. It describes the actual quality or safety of a measurement result. For this reason, the measurement uncertainty is not referred to as “measuring error“ in this document, as is often the case in literature. The measurement uncertainty is a piece of additional information in order to complete the measurement result. It must not be mistaken for an incorrect measurement result.

VDA Volume 5 refers to repeatable processes measuring geometrical characteristics, such as the measurement of lengths and angles.

Its applicability to destructive tests, rapidly changing measured quantity values or other physical quantities has not been validated and must be verified in each individual case.

In addition, this document describes practical procedures in order to make a measurement systems analysis and to calculate the measurement uncertainty of measurement processes.

It deals with the following issues:

- capability of measuring systems
- short-term evaluation of the capability of entire measurement processes (with and without the influence of the test parts' form deviation, acceptance of measuring systems (measuring instruments), comparison of several places of measurement, measuring systems for the same measurement tasks)
- long-term analysis of the capability of entire measurement processes over a significant period (e.g. for several days)
- determination of the expanded measurement uncertainty in order to consider information about conformity according to ISO/TS 14253 Part 1 [13]
- ongoing evaluation of the capability of a measurement process (stability of a measuring instrument)

It is also about specific features, such as

- test characteristics with narrow tolerances
- classifications.

Within the quality management system, it is important to determine the field of application of this document, i.e. the processes or characteristics it applies to. A schematic approach helps to reach the reproducibility of the test results and facilitates its application in practice for users.

This document is an enhanced version of the VDA Volume 5 "Capability of Measurement Processes", 2003 edition. Its basic approach is to compare the measurement uncertainty or components of it, to the tolerance to be tested and to use this ratio as evaluation criterion. The procedures of the MSA manual (Measurement Systems Analysis) [1] established in practice can be included.

3 Terms and Definitions

3.1 General Terms and Definitions

The following sections define the most important terms used in this document. Moreover, the terms and definitions according to ISO 3534-1 [9], ISO 10012 [12], VIM (International vocabulary of metrology) [21], ISO/IEC Guide 98-3 (GUM) [22], ISO/TS 14253 [13] and DIN 1319 [5] [6] [7] are applied.

The definitions of most of the following terms are taken from standards (see reference). Colloquially, some other expressions are often used for some of the terms defined in this chapter. These expressions are added in parentheses. They are also used in the text.

Measurement uncertainty [22]

Parameter, associated with the result of a measurement that characterizes the dispersion of the values that could reasonably be attributed to the measurand.

Note 1: The parameter may be, for example, a standard deviation (or a given multiple of it), or the half-width of an interval having a stated level of confidence.

Note 2: Uncertainty of measurement comprises, in general, many components. Some of these components may be evaluated from the statistical distribution of the results of series of measurements and can be characterized by experimental standard deviations. The other components, which can also be characterized by standard deviations, are evaluated from assumed probability distributions based on experience or other information.

Note 3: It is understood that the result of the measurement is the best estimate of the value of the measurand and that all components of uncertainty, including those arising from systematic effects, such as components associated with corrections and reference standards, contribute to the dispersion.

Standard uncertainty $u(x_i)$ [22]

(standard measurement uncertainty or uncertainty component)

Uncertainty of the result of a measurement expressed as a standard deviation.

Uncertainty budget (for a measurement or calibration)

Table summarizing the results of the estimations or statistical evaluations regarding the uncertainty components contributing to the uncertainty of a measurement result (see Table 5).

Note 1: The uncertainty of a measurement result is only clear if the measurement procedure (including the test part, measurand, measurement method and conditions of measurement) is defined.

Note 2: The designation "budget" is associated with numerical values attributed to the uncertainty components, their combinations and extension based on the measurement procedure, the conditions of measurement and assumptions.

Combined standard uncertainty $u(y)$ [22]

(combined standard measurement uncertainty)

Standard uncertainty of the result of a measurement when that result is obtained from the values of a number of other quantities, equal to the positive square root of a sum of terms, the terms being the variances or covariances of these other quantities weighted according to how the measurement result varies with changes in these quantities.

Coverage factor k [22]

Numerical factor used as a multiplier of the combined standard uncertainty in order to obtain an expanded uncertainty (see Table 4 and Annex D).

$$U_{MS} \text{ or } U_{MP} = k \cdot u(y)$$

Expanded measurement uncertainty (expanded uncertainty) [22]

Quantity defining an interval about the result of a measurement that may be expected to encompass a large fraction of the distribution of values that could reasonably be attributed to the measurand.

Note 1: The fraction may be viewed as the coverage probability or level of confidence of the interval.

Note 2: To associate a specific level of confidence with the interval defined by the expanded uncertainty requires explicit or implicit assumptions regarding the probability distribution characterized by the measurement result and its combined standard uncertainty. The level of confidence that may be attributed to this interval can be known only to the extent to which such assumptions may be justified.

Remark: The GUM [22] and ISO/TS 14253 [13] use the formula symbol U for the expanded measurement uncertainty. The latest standards, such as 3534-2 [9], refer to the upper tolerance limit as U . In order to avoid confusions, this document uses the symbol U_{MS} for the expanded measurement uncertainty where the text refers to a measuring system and U_{MP} where the text refers to a measurement process.

Testing (conformity assessment) [17]

Determining one or more characteristics on an object included in the conformity assessment, according to a certain procedure.

Conformity [10]

Fulfilment of a requirement.

Operator [18]

Person possessing the relevant professional and personal qualifications in order to conduct an inspection and evaluate the results.

Test characteristic [20]

Characteristic the inspection is based on.

Characteristic [21]

Distinguishing feature.

Value of the characteristic (measured quantity value) y_i [20]

Form of the value attributed to the characteristic.

Measurement result (result of measurement) Y [21]

Set of quantity values being attributed to a measurand together with any other available relevant information.

Note: A measurement result is generally expressed as a single measured quantity and a measurement uncertainty $Y = y_i \pm U_{MP}$. If the measurement uncertainty is considered negligible for some purpose, the measurement result may be expressed as a single measured quantity value. In many fields, this is the common way of expressing a measurement value.

Bias / B_i [21]

Estimate of a systematic measurement error.

MSA [1]

MSA refers to Measurement Systems Analysis. The MSA manual presents guidelines of the QS-9000 for the assessment and acceptance of measuring equipment.

ANOVA

ANOVA (Analysis of Variance) represents a mathematical approach in order to determine variances. Based on these variances, standard uncertainties can be estimated.

Measurement repeatability (repeatability) [21]

Measurement precision under a set of repeatability conditions of measurement.

Intermediate measurement precision (intermediate precision) [21]

Measurement precision under a set of intermediate precision conditions of measurement.

Inspection by variables (measuring)

Determination of a specific value of a measurand as a multiple or a component of an item or of a specified reference system. Measuring means to draw a quantitative comparison between the measurand and the reference value by using a measuring instrument or measuring equipment.

Inspection by attributes (gauging)

Comparison of a test part to a gauge in order to find out whether a specified limit is exceeded. The actual deviation of the tested quantity from the nominal quantity value is not determined.

True quantity value (true value) [21]

Value consistent with the definition of an observed, specific quantity.

Note 1: This value would be obtained by a perfect measurement.

Note 2: True values are by nature indeterminate.

Conventional true value (of a quantity) [22]

Value attributed to a particular quantity and accepted, sometimes by convention, as having an uncertainty appropriate for a given purpose.

Note 1: Conventional true value is sometimes called assigned value, best estimate of the value, conventional value or reference value.

Note 2: Frequently, a number of results of measurements of a quantity are used to establish a conventional true value.

Measurement standard [21]

Realization of the definition of a given quantity, with stated quantity value and associated measurement uncertainty used as a reference.

Working measurement standard (working standard) [21]

Measurement standard that is used routinely to calibrate or verify measuring instruments and measuring systems.

Calibration [21]

Operation that, under specified conditions, in a first step, establishes a relation between the quantity values with measurement uncertainties provided by measurement standards and corresponding indications with associated measurement uncertainties and, in a second step, uses this information to establish a relation for obtaining a measurement result from an indication.

Note: Calibration should not be confused with adjustment of a measuring system, often mistakenly called “self-calibration“.

Remark: Comparison measurement taken under specified conditions between a more precise calibration device and the object to be calibrated in order to estimate the systematic measurement error.

Adjustment [21]

Set of operations carried out on a measuring system so that it provides prescribed indications corresponding to given values of a quantity to be measured.

Note 1: Adjustment of a measuring system should not be confused with calibration, which is a prerequisite for adjustment..

Note 2: After an adjustment of a measuring system, the measuring system must usually be recalibrated.

Remark: Elimination of the systematic measurement error of the object to be calibrated **are** estimated in the calibration. Adjustment includes all actions required in order to minimize the deviation of the final indication.

Metrological traceability [21] and [3]

Property of a measurement result whereby the result can be related to a reference through a documented unbroken chain of calibrations, each contributing to the measurement uncertainty.

Setting

Setting means to set measuring systems to a measure referring to material measures. If the aim of this operation is a zero indication, it is referred to as zero setting.

Remark: Setting means to transfer the calibrated actual value of the working measurement standard (material measure) to the measuring instrument under real operating conditions. Users make their measuring instruments ready for operation on site.

Adjustment minimizes systematic measurement errors.

Measuring instrument [21]

Device used for making measurements, alone or in conjunction with one or more supplementary devices.

Note 1: A measuring instrument that can be used alone is a measuring system.

Note 2: A measuring instrument may be an indicating measuring instrument or a material measure.

Measuring equipment [10]

Measurement instrument, software, measurement standard, reference material or auxiliary apparatus or combination thereof necessary to realize a measurement process.

Resolution [21]

The smallest change in a quantity being measured that causes a perceptible change in the corresponding indication.

Measuring system [21]

Set of one or more measuring instruments and often other devices, including any reagent and supply, assembled and adapted to give information used to generate measured quantity values within specified intervals for quantities of specified kinds.

Capability of the measuring system

Qualification of the measuring system for a specific measurement task exclusively taking into account the required accuracy of measurement (measurement uncertainty U_{MS}) (see Chapter 4.7).

Maximum permissible measurement error (error limit) MPE [21]

Extreme value of measurement error, with respect to a known reference quantity value, permitted by specifications or regulations for a given measurement, measuring instrument, or measuring system.

Note: Usually, the term “maximum permissible errors“ or “limits of error“ is used where there are two extreme values.

Measurement process [21]

Interaction of interrelated operating resources, actions and influences creating a measurement.

Note: Operating resources can be both, human and materials.

Measurement process capability

Qualification of the measurement process for a specific measurement task exclusively taking into account the required accuracy of measurement (expanded measurement uncertainty U_{MP}) (see Chapter 4.7).

Remark: In general, the measuring system or measurement process capability analysis is a short-term evaluation. Especially in case of new measuring systems or measurement processes, the stability of a measuring instrument should be determined over a significant period and considered in order to prove capability.

Stability of a measuring instrument (stability) [21]

Property of a measuring instrument, whereby its metrological properties remain constant in time.

Note: Stability may be quantified in several ways:

Example 1: In terms of the duration of a time interval over which a metrological property changes by a stated amount.

Example 2: In terms of the change of a property over a stated time interval.

Remark: Inspection of the stability must be demonstrated by means of an ongoing review of the capability of the measurement process (see Chapter 6).

Specified Tolerance [9]

Difference between the upper specification limit U and lower specification limit L.

Verification [21]

Provision of objective evidence that a given item fulfils specified requirements.

Example 1: Confirmation that a given reference material as claimed is homogeneous for the quantity value and measurement procedure concerned, down to a measurement portion having a mass of 10 mg.

Example 2: Confirmation that a target measurement uncertainty can be met.

Validation [21]

Verification, where the specified requirements are adequate for an intended use.

Example 1: A measurement process must be determined with sufficient accuracy due to its interpretation of the “diameter” level. Validation ensures the capability of the measurement process needed for the specified size of the diameter (e.g. nominal value) and the demanded tolerance.

Example 2: see Chapter 8.3

Control chart

Control chart, also referred to as quality control chart or QCC, is applied to statistical process control. A QCC generally consists of a “level” path and a “variation” path together with specified action limits. Statistical values such as sample means and sample standard deviations are plotted on the respective path of the QCC.

3.2 Proof of Conformance or Non-conformance with Tolerances according to ISO/TS 14253 [13]

Part 1 of ISO/TS 14253 establishes the rules for determining when the characteristics of a specific work piece or measuring equipment are in conformance or non-conformance with a given tolerance (for a work piece) or limits of maximum permissible errors (for measuring equipment), taking into account the uncertainty of measurement.

It also gives rules on how to deal with cases where a clear decision (conformance or non-conformance with specification) cannot be taken, i.e. when the measurement result falls within the uncertainty range (see Figure 1) that exists around the tolerance limits.

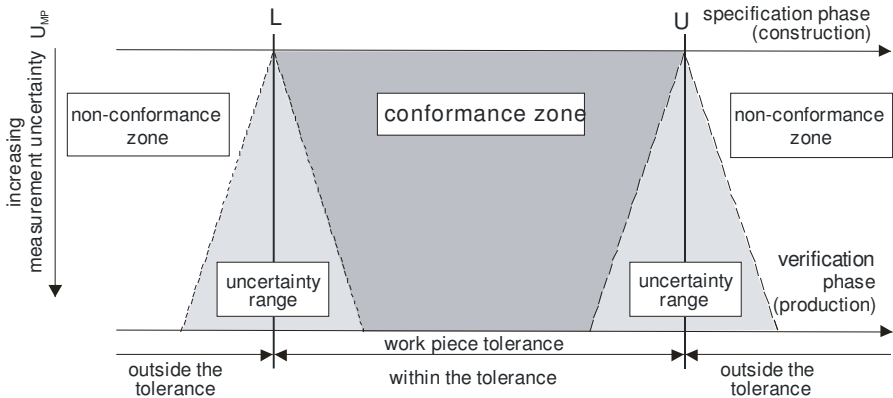

Figure 1: Uncertainty ranges and conformance or non-conformance zones

Conformance

Fulfilment of specified requirements.

Conformance zone

Specification zone reduced by the expanded uncertainty of measurement U_{MP} (Figure 2).

Note: The specification is reduced by the expanded uncertainty of measurement U_{MP} at the upper and lower specification limits. In case of characteristics with a one-sided specification, this reduction does not apply to the natural boundary side.

Proof of conformance

If the measurement result Y (measured quantity value y_i associated with the expanded measurement uncertainty U_{MP}) is lying within the specification zone, the conformance with the tolerance is proved and the product can be accepted.

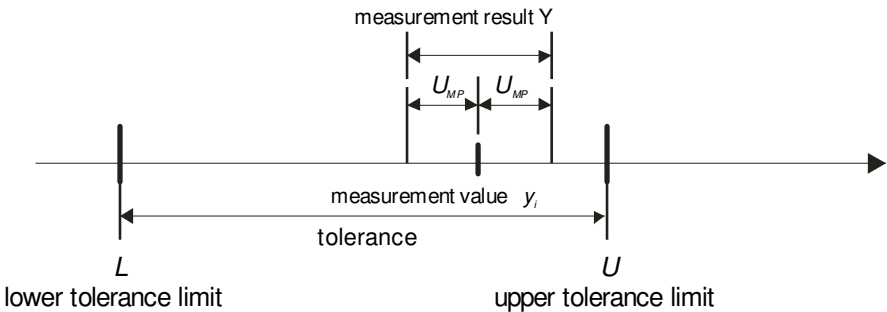

Figure 2: Proof of conformance with the tolerance

Non-conformance

Non-fulfilment of a specified requirement.

Non-conformance zone

Zone(s) outside the specification zone extended by the expanded uncertainty of measurement U_{MP} (Figure 1).

Note: The specification is extended by the expanded uncertainty of measurement U_{MP} at the upper and lower specification limit. In case of characteristics with a one-sided specification, this reduction does not apply to the natural boundary side.

Proof of non-conformance

Non-conformance with the tolerance is proved when the measurement result Y (measured quantity value y_i associated with the expanded measurement uncertainty U_{MP}) is lying beyond the specification zone (Figure 3). In this case, the work piece must be rejected.



Figure 3: Proof of non-conformance with the tolerance

Uncertainty ranges

Areas near the specification limits where conformance or non-conformance cannot clearly be determined because of the measurement uncertainty (Figure 1). When the measurement result Y (measured quantity value y_i associated with the expanded measurement uncertainty U_{MP}) includes one of the specification limits, neither conformance or non-conformance can be proved (Figure 4).

Note 1: Uncertainty ranges are symmetrical to the specification limits.

Note 2: As a result, work pieces can neither be automatically accepted nor rejected. For such “dead end cases”, it is advisable to follow the rule below:

Reduce the uncertainty of measurement and thereby reduce the uncertainty range in order that conformance or non-conformance can clearly be demonstrated.

Mutual agreement between customers and manufacturers:

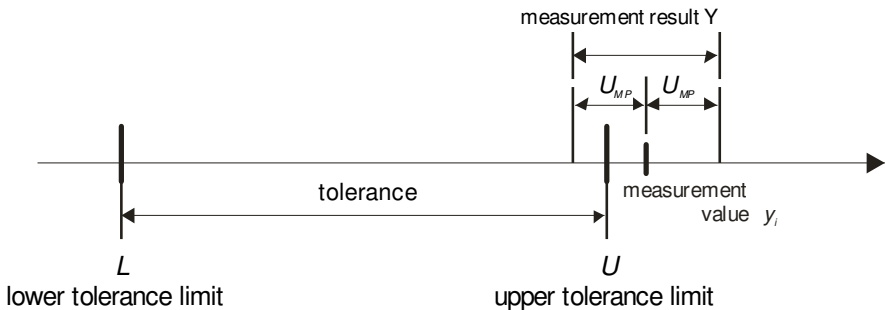

Figure 4: Conformance or non-conformance with the tolerance can be proved

4 General Procedure for Establishing the Capability of Measurement Processes

Inspections for series production control and conformity assessments require characteristics that are identified correctly as characteristics in conformance, i.e. “o.k.” (within the specification limits), or in non-conformance, i.e. “n.o.k.” (beyond the specification limits), with the tolerance. It is important to consider the measurement error caused by the variation of the production process as well as errors caused by the measurement process. Measurement errors caused by the measurement process lead to an uncertain measurement result and thus to dubious decisions. Errors must be known and can only be accepted to a certain degree relating to the specified tolerance of the inspection.

4.1 Influences Causing the Uncertainty of Measurement Results

Influences caused by measuring systems, operators, test parts, environment, etc. usually affect the measurement result (see Figure 5) as random errors.

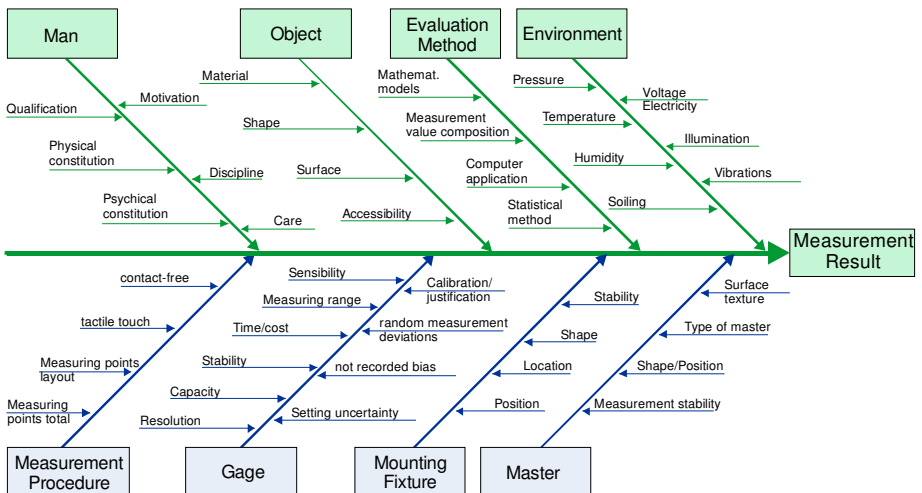

Figure 5: Important influences on the uncertainty of measurement results

The following sections provide some examples of frequently recurring and important influence components that are described in detail in Chapter 5 and Table 14.

Measurement standard / reference standard

Depending on the quality of the measurement standard, it could lead to a considerable proportion of the uncertainty of the measurement result. The calibration certificate normally contains the respective uncertainty. The traceability of the standard used must be demonstrated.

Measuring equipment / measuring system

Important influence components associated with the measuring system are

- resolution
- reference standard
- setting to one or several test parts
- linearity deviation / systematic measurement error
- measurement repeatability

Environment

Important influence components of the environment affecting the measurement process are

- temperature
- lighting
- vibrations
- contamination
- humidity

The influence of temperature variations on a test part, measuring system and clamping device are particularly significant in terms of environmental conditions. In case of measurements of lengths, this fact leads to different measurement results when the temperature changes.

Table 11 and Annex B provide recommendations for the determination of the standard measurement uncertainty from temperature.

Human / operator

Influences of operators leading to the uncertainty of measurement results are caused by the different qualifications and skills of operators in taking measurements.

- different measuring forces
- reading errors because of parallaxes
- physical and psychological constitution of the operator
- qualification, motivation and care

Test part

Influences from test parts can be detected when, for example, the same characteristic is measured at different points on the test part.

It results from, for example:

- geometrical deviations (form deviations and changes in the surface texture)
- material properties (e.g. elasticity)
- lack of inherent stability

Measurement method / measurement procedure

The way a measurement is taken or the selected sampling strategy has an impact on the measurement result. Even the applied mathematical procedures for determining a measured quantity value are influencing the result.

Mounting device

If measuring instruments are built into installations, they will also affect the measurement result.

Evaluation method

The mathematical and statistical procedures used for evaluation (e.g. elimination of detected outliers or filtering) can have an effect on the result.

4.2 General Information

The evaluation of measurement processes and the consideration of the measurement uncertainty are based on the following table (Table 2).

<i>Input information</i>	<i>Description</i>	<i>Result</i>
Information about the measuring system, the test characteristic and about the measurement standards (references)	Measuring system capability analysis	Expanded measurement uncertainty U_{MS} capability ratio Q_{MS} (see Chapter 5.2)
Information about the measurement process and the test characteristic including all uncertainty components to be considered	Measurement process capability analysis	Expanded measurement uncertainty U_{MP} capability ratio Q_{MP} (see Chapter 5.3)
Information about the test characteristic and the corresponding expanded measurement uncertainty U_{MP}	Conformity assessment including the expanded measurement uncertainty	Conformance or non-conformance zone (see ISO/TS 14253 [13])
Information from measuring system, measurement process and about the test characteristic	Ongoing review of the capability of the measurement process	Control chart including the calculated action limits (see Chapter 6)

Table 2: General procedures for establishing the capability of measurement processes

In order to prove the capability of a measurement process, all relevant uncertainty components affecting the measurement result must be considered. Moreover, the specifications of the test characteristic must be known in order to establish the capability of the measuring system and in order to prove the capability of the measurement process.

A measurement process capability analysis requires the estimation of the expanded measurement uncertainty U_{MP} . The capability ratio Q_{MP} is used as an evaluation criterion. The value of the expanded measurement uncertainty U_{MP} is available for consideration in decision rules for proving conformance or non-conformance according to ISO/TS 14253 Part 1 [13].

Ongoing monitoring provides proof of the stability of a measuring instrument and shows long-term influences. The following sections describe the single procedures.

4.3 Specific Approaches

4.3.1 Measurement Errors

Measurement errors in a measurement process consist of known and unknown systematic errors from a number of different sources and causes. In German, the traditional term “measuring error” has been replaced by the term “measurement deviation” since the publication of DIN 1319:1995. In case of measuring instruments or measuring systems, the permissible systematic errors prescribed by different standards and guidelines (e.g. VDI/VDE/DGQ 2618 ff [28]) are referred to as maximum permissible error or error limit.

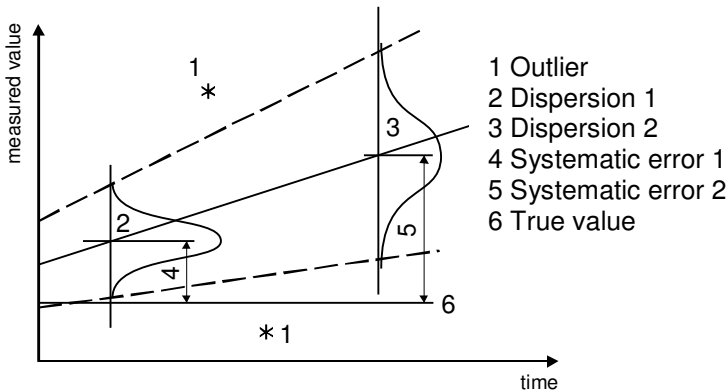

Figure 6: Measurement errors in results of measurements [13]

Different types of measurement errors (see Figure 6) show up in measurement results:

- **random measurement errors**

Random errors are caused by non-controlled random influence factors. They may be characterized by the standard deviation and the type of distribution (see Dispersion 1 and 2 in Figure 6).

- **systematic measurement errors (known, unknown)**

Systematic errors (see Chapter 5.2.2) may be characterized by size and sign (+ or -):

$$Bi = y_i - \text{true value} \quad (6) \text{ see Figure 6}$$

The difference between the reference value of a measurement standard and the mean of the measured values often form the basis for calculating the systematic measurement error:

$$Bi = |\bar{x}_g - x_m|$$

\bar{x}_g arithmetic mean of the measured values

x_m reference value of the measurement standard

Where measurement errors are not regarded as systematic, the cause of the measurement error has not been sought for economic and complexity reason or the resolution is inadequate (e.g. %RE greater 5% of the specification; see Chapter 5.2.1).

Remark: Bias is not regarded as a constant but a random variable.

- **instrumental drift**

Drift is caused by a systematic influence of non-controlled influence factors. It is often a time effect or a wear effect. Drift may be characterized by change per unit time or per amount of use. Instrumental drifts characterized by change per unit time must be recorded in a "long-term experiment" (over several days) prior to the first application of the measuring instrument and the drifts have to be considered in series production (e.g. in the form of an instruction: "switch on measuring instrument 20 minutes before use"). If required, instrumental drifts caused by wear effects must be assessed by reviewing the stability of the measuring instrument (e.g. control chart).

- **outlier**

Outliers are caused by non repeatable incidents in the measurement. Noise – electrical or mechanical (e.g. voltage peaks and vibrations) – may result in outliers. A frequent reason for outliers is human mistakes as reading and writing errors or mis-handling of measuring equipment. Outliers are impossible to characterize in advance, but they might occur in an experiment.

- Remark 1:** Frequently applied methods to determine the capability of measuring equipment include consideration of the systematic measurement error with regard to a measurement standard representing the true value. In many cases, however, the measurement standards used in production (working standards) are not identical to the test parts measured in series production. This could lead to unexpected measurement errors. In order to ensure that these errors are sufficiently minor, some representative test parts should be measured by means of a superior measurement procedure (e.g. prior to release). The results are compared and evaluated. The reproducibility of the measurement method is crucial.
- Remark 2:** Production-related measuring instruments are often based on comparison measurements. Setting an instrument with the help of a working standard means correcting the systematic measurement error. A repeatability test using the same working standard normally leads to a smaller bias.
- Remark 3:** Further measurement errors could occur in measurements at several measuring points and where different measuring systems or measurement procedures are used for one measurement task. In order to guarantee reproducible measurement results for all systems and procedures used, these errors must be analyzed in experiments.

4.3.2 Long-term Analysis of Measurement Process Capability

The known procedures for capability analyses and the capability of measuring systems and measurement processes are conducted over a period of several minutes up to several hours. However, the results are only “short-term conclusions” and do not give any information about the long-term behaviour of the determined values.

In order to gain profound information, the required inspections should be made several times over a reasonable, significant period. For further information about the estimation of uncertainty components see Table 14.

4.3.3 Reproducibility of Identical Measuring Systems

In many cases, several identical but independent measuring systems are used for measurement processes with the same measurement task. An alternative is to combine the identical, independent measuring systems into an overall measuring system for a specific measurement task. Each one of these individual measuring systems is regarded as separate measurement process.

The aim of this analysis is to ensure the reproducibility of the single measuring systems by means of the variation and the measurement error. It is im-

portant to inspect reference standards and parts. For further information about the estimation of uncertainty components see Table 14.

4.4 Standard Uncertainties

The GUM [22] “Guide to the expression of uncertainty in measurement” describes how to determine the measurement uncertainty specific to the respective measurement task. The standard uncertainties for every relevant influence factor are estimated using the mathematical model of the measurement process. Standard uncertainties quantify the single uncertainty components. According to the law of propagation of uncertainty, sensitivity coefficients are partial derivatives of the respective equation of the measurement model with regard to each single influence factor. An uncertainty budget summarizes standard uncertainties, associated sensitivity coefficients and the calculated combined and expanded measurement uncertainties.

In the practice of industrial applied metrology, a special case of mathematical model (sum/difference or product/quotient) is assumed where the sensitivity coefficients equal “1”. This leads to a simple quadratic addition of the uncertainties (see Chapter 4.5).

Remark: Complex, technical interactions (such as wear, contamination, manufacturer’s specifications, form deviations, positioning accuracy, vibrations, etc.) that are hard to express mathematically are considered in the experiment in the form of a sum result.

The standard uncertainty $u(x_i)$ can be estimated by

- the statistical evaluation of series of measurements

Type A evaluation

or by

- the use of available information

Type B evaluation

The standard uncertainties estimated by means of the Type A and Type B evaluations are equal.

4.4.1 Type A Evaluation (Standard Deviation)

In the simplest case, the standard deviation s_g of n individual observations is calculated from a series of n observations obtained under the same specified conditions of measurement:

$$s_g = \sqrt{\frac{\sum_{i=1}^n (x_i - \bar{x})^2}{n-1}}$$

In order to determine the standard deviation s_g , $n = 25$ repeated measurements are recommended. This experiment is generally only conducted once in the estimation of measurement uncertainty.

The standard deviation will be considered in the measurement uncertainty budget in the form of the standard measurement uncertainty $u(x_i)$ if, as is usual in practice, the measurement result is obtained in one measurement only.

$$u(x_i) = s_g$$

A lower value for $u(x_i)$ is achieved by taking several repeated measurements with the sample size $n^* > 1$

$$u(x_i) = \frac{s_g}{\sqrt{n^*}}$$

as the standard measurement uncertainty of the mean of all the sample values (see Annex C).

4.4.2 Type A Evaluation (ANOVA)

In addition to the procedures described here for determining only one uncertainty component $u(x_i)$ of an influence factor, there is also a statistical technique used to identify and quantify the effects of several influence factors in an experiment. This procedure has been applied to capability analysis according to the MSA manual (Measurement Systems Analysis [1]) for years. In order to calculate the %GRR (Gage Repeatability & Reproducibility), the operator and equipment variation is estimated in an experiment (e.g. 3 operators measure each of 10 test parts twice: $3 \cdot 10 \cdot 2 = 60$ measurements).

In this case, the method of ANOVA (Analysis of Variance) is used as described Annex A.

Remark: The MSA manual [1] describes the method of ANOVA and the Average Range Method (ARM). Under statistical considerations, the method of ANOVA should be preferred to the ARM, the more so as the method of ANOVA also evaluates interactions. The method of ANOVA is indeed more complex in a mathematical sense, but the use of specific computer software makes its application easy.

In the same experiment, further influence factors, such as the uncertainty from test parts or different measuring systems can be evaluated, as is strongly recommended in Chapter 3.4.1 of the ISO/IEC Guide 98-3 (GUM) [22]. However, each additional influence factor increases the effort for this experiment considerably. In case of the example described above, the uncertainty from test part non-homogeneity could be determined by prompting each operator to measure each test part at four different measuring points twice. This would lead to $3 \cdot 10 \cdot 4 \cdot 2 = 240$ measurements. The required effort is economically not feasible. For this reason, the GUM [22] states: "This is rarely possible in practice due to limited time and resources". There are two alternatives in order to minimize this effort:

Reducing the number of experiments

Design of experiments provides procedures for reducing the number of experiments without any major loss of information. It is recommended to use D-optimum experimental designs in the case of multistage factors. The estimation of variance components is based on the method of moments (ANOVA see Annex A.2). The corresponding experimental design can be created by suitable computer software automatically according to specified information about the experiment.

Example for a D-optimum experimental design

In order to estimate the standard uncertainty from the reproducibility of operators u_{AV} , the uncertainty from the maximum value of repeatability or resolution u_{EV} and from test part non-homogeneity u_{OBJ} , 3 operators and 2 repeated measurements on each of 10 parts at each of 4 measuring points are required. This leads to 240 individual measurements. If a D-optimum design with a twofold interaction is created under the same conditions, the original 240 individual measurements can be reduced to 128 measure-

ments. This almost halves the number of experiments. The example of Annex F.2 illustrates this option.

Observation of a maximum of two influence factors

If the example above only evaluates the influence of operators and equipment, the number of measurements is reduced. Alternatively, it is possible to evaluate two other influence factors (e.g. influence of test part and measuring instrument). Any other influence factor that is still missing is determined according to the Type A or Type B evaluation described above. Some variations might be included in several calculations. However, it is important not to consider them more than once in the evaluation of the measurement process.

If, for example, the standard uncertainty u_{GV} should be evaluated because of different measuring systems (e.g. micrometer), 1 operator can take 2 repeated measurements on each of 10 test parts from 3 identical measuring systems ($1 \cdot 10 \cdot 2 \cdot 3 = 60$ measurements). In order to minimize the influence of the test parts, both repeated measurements should always be taken at the same measuring point. Thus, it is important to mark the measuring point used in the first measurement.

4.4.3 Type B Evaluation

If the standard uncertainty cannot be determined by the Type A evaluation or if this method is economically not feasible, the respective standard uncertainties are estimated based on available information. The pool of information may include:

- previous measurement data
- experience with or general knowledge of the behaviour and properties of relevant materials and instruments (similar or identical instruments)
- manufacturer's specifications
- data provided in calibration and other certificates
- uncertainties assigned to reference data taken from handbooks
- measured quantity values based on less than $n = 10$ measurements

4.4.3.1 Type B Evaluation: Expanded Measurement Uncertainty U_{MP} Known

If the available information provides numerical values for the expanded measurement uncertainty U_{MP} and the used coverage factor k , e.g. from calibration certificates, the coverage factor k must be calculated as follows before multiplying it by the combined standard uncertainty $u(y)$, see Chapter 4.6.

$$u(x_i) = \frac{U_{MP}}{k}$$

4.4.3.2 Type B Evaluation: Expanded Measurement Uncertainty U_{MP} Unknown

If the expanded measurement uncertainty is unknown, a variation limit a or another upper or lower limit can be selected. The standard uncertainty $u(x_i)$ is calculated in consideration of the respective distribution type by transforming the limits of error. Table 3 contains typical distributions. Without any information about the distribution, the rectangular distribution is the safest alternative.

$$u(x_i) = a \cdot b \quad \text{where} \quad \begin{array}{l} a \text{ variation limit} \\ b \text{ distribution factor} \end{array}$$

According to the International vocabulary of metrology [21], the maximum permissible measurement error is the maximum value of a measurement error relating to a known reference value. This reference value must be given in the specifications or regulations for a measurement, measuring instrument or a measuring system.

The distribution factor depends on the respective distribution type (see Table 3). In estimating the standard uncertainty of the resolution of the measuring system, the rectangular distribution applies. If the range R is used as an estimator of the variation resulting from several repeated measurements (e.g. taken from a measurement standard), the distribution factor of the normal distribution ($b = 0,5$) is applied.



Distribution type	Function (P = probability that the values lie within the interval $\pm a$)	Distribution factor b	Standard uncertainty $u(x)$
Normal distribution (Gaussian distribution)	 ($P = 95,45\%$)	0,5	$u(x_i) = 0,5 \cdot a$
Rectangular distribution	 ($P = 100\%$)	$\frac{1}{\sqrt{3}}$	$u(x_i) = \frac{a}{\sqrt{3}}$

Table 3: Typical distribution types and associated variation limits for determining the standard uncertainty by the Type B evaluation

4.5 Combined Standard Uncertainty

In accordance with the mathematical model, the combined standard uncertainty $u(y)$ is calculated from all standard uncertainty components obtained in the Type A and Type B evaluation. However, in the special cases described in Chapter 4.4 where the sensitivity coefficients equal “one”, the combined measurement uncertainty is calculated using quadratic addition:

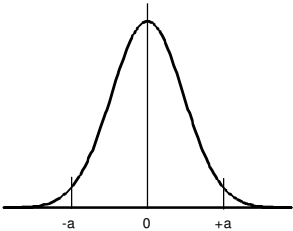
$$u(y) = \sqrt{\sum_{i=1}^n u(x_i)^2} = \sqrt{u(x_1)^2 + u(x_2)^2 + u(x_3)^2 + \dots}$$

4.6 Expanded Measurement Uncertainty

A measure of uncertainty with which the true value may vary from the measured value is termed expanded measurement uncertainty U_{MP} . It is calculated by multiplying the combined measurement uncertainty by the coverage factor k (see Table 4):

$$U_{MP} = k \cdot u(y)$$

The expanded measurement uncertainty U_{MP} is calculated from a two-sided, limited probability density function of the combined measurement uncertainty based on a level of confidence of $P = 1 - \alpha = 0,9545$ with an interval of $\alpha/2$ beyond the distribution quantiles.

The special case of a symmetric distribution leads to the following calculation formula of the expanded measurement uncertainty: $U_{MP} = k \cdot u(y)$ and by assuming a normal distribution $k = z_{1-\alpha/2} = 2$.

Assuming a normal distribution, the values and intervals of Table 4 apply.

Coverage factor	Level of confidence
1	68,27%
2	95,45%
3	99,73%

Table 4: Coverage factors

If the probability density function does not follow a normal distribution (e.g. in case of an asymmetric distribution), high levels of confidence, in particular, can lead to sharp deviations from the values listed above (see Annex D).

Remark: The level of confidence of 95,45% and the coverage factor $k=2$ is recommended for calculating the capability of measuring systems and measurement processes.

These assumptions allow for a statement about the probability that the true quantity value of the measurand y_i lies within the interval.

$$y_i - U_{MP}, \dots, y_i + U_{MP}$$

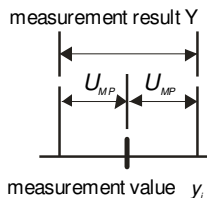

4.7 Calculation of Capability Ratios

When inspecting by variables (measuring), the capability of a measurement process is established by determining the expanded measurement uncertainty specific to the respective measurement task in consideration of each dominant influence factor (see Chapter 4.1). The characteristics and specifications to be tested must be determined before the inspection starts. Figure 7 shows a flow chart for assessing the capability of measuring systems or measurement processes.

In case of inspections by attributes (gauging), special analyses are required in order to establish the capability of measurement processes (see Chapter 9).

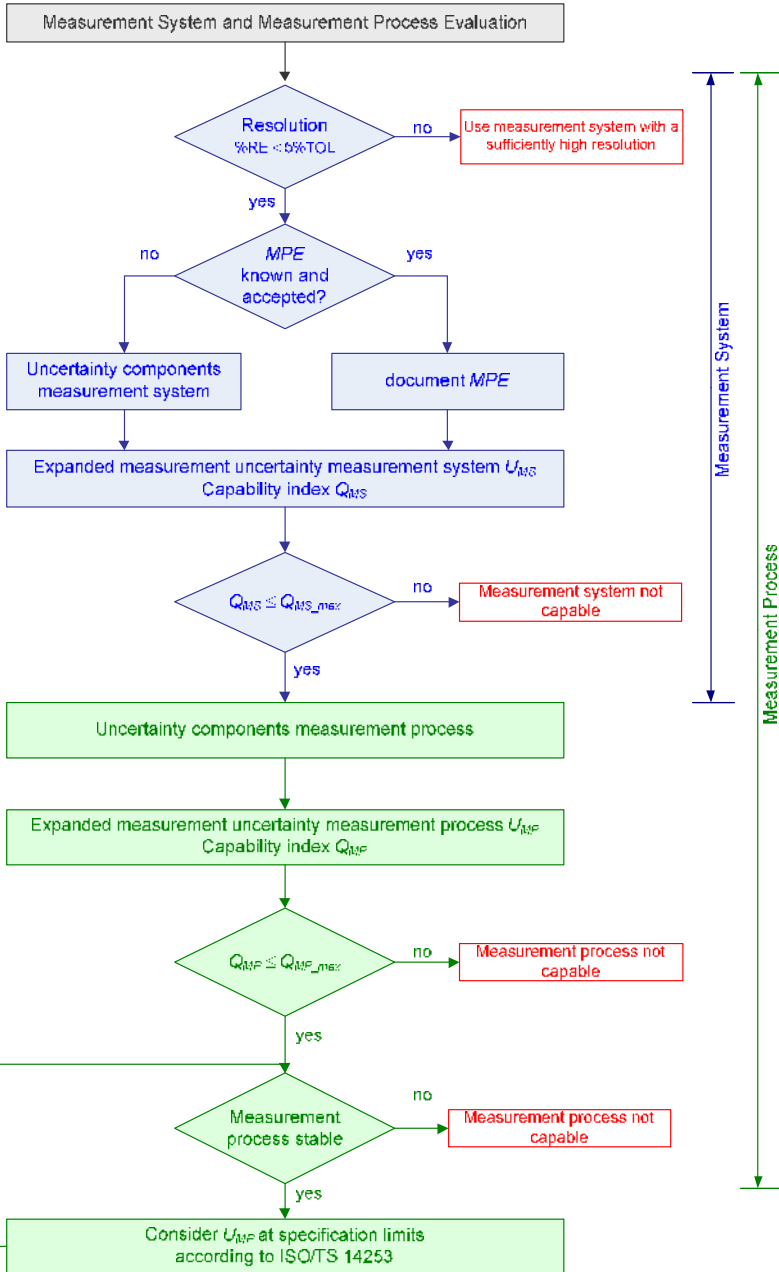

Figure 7: Flow chart for assessing the capability of measurement processes

The capability ratios Q_{MS} for the measuring system and Q_{MP} for the measurement process help to evaluate metrological demands on the measuring system or measurement process. They are defined as capability ratios and expressed as percentages.

$$Q_{MS} = \frac{2 \cdot U_{MS}}{TOL} \cdot 100\% \quad \text{or} \quad Q_{MP} = \frac{2 \cdot U_{MP}}{TOL} \cdot 100\%$$

The capability ratios are associated with the respective limits $Q_{MS_{max}}$ or $Q_{MP_{max}}$. If it is demonstrated that the capability ratios

$$Q_{MS} \leq Q_{MS_{max}} \quad \text{or} \quad Q_{MP} \leq Q_{MP_{max}},$$

do not exceed these limits, the capability of the measuring system or measurement process is established.

Remark:

According to ISO/TS 14253 [13], the tolerance zone is reduced on either side by the expanded measurement uncertainty U_{MP} . For this reason, the ratio of $2 \cdot U_{MP}$ is used as the tolerance TOL for the capability ratio.

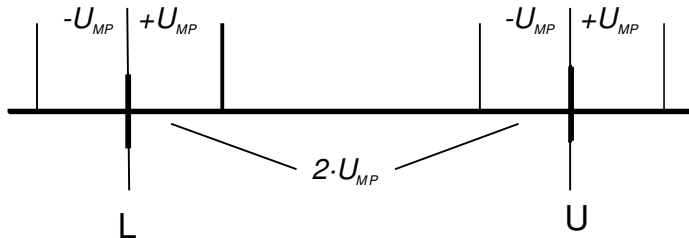

Figure 8: Illustration of a capability ratio

The limits for the capability of measuring systems and measurements processes must be determined. It is important to consider that the influences of the form deviation of test parts can affect the evaluation of the measurement process considerably. It is recommended that the capability ratio for measuring systems, $Q_{MS_{max}}$ amounts to 15% and, for measurement processes, $Q_{MP_{max}}$ amounts to 30%.

Remark 1: The proposed limits serve as guide values that cannot be generalized in any case. In individual cases, the limits must be agreed upon between supplier and customer. If the proposed limits are unrealistic, individual agreements must be made depending on the respective characteristic and its specifications (wide or narrow/very narrow tolerances). It is important always to take into account the entire measurement process. In order to determine the limits, it is necessary to consider the economic and technical requirements. For this reasons, the limits should be as wide as possible and as narrow as necessary.

Remark 2: If the capability of the production process reaches a sufficiently high value (e.g. $C_p, C_{pk} \geq 2,0$) that was established by an adequate measurement process, a separate observation of the expanded measurement uncertainty at the specification limits is not required because the evaluation of the process already includes the variation of the measurement process.

The capability ratio Q_{MP} corresponds to the percentage by which the tolerance zone of the test characteristic is reduced or extended according to ISO/TS 14253 Part 1 [13]. Chapter 4.10 illustrates the relation between the observed capability index and the real capability index in case of a two-sided tolerance zone for various Q_{MP} values. As shown in Figure 9 and Table 6, the effects can be significant.

Remark: Determination of the uncertainty components of the measuring system is not required when the *MPE* has been proved and documented:

$$u_{MS} = MPE / \sqrt{3}$$

If more than one *MPE* value affects the combined standard uncertainty of the measuring system, the following formula applies:

$$u_{MS}^2 = \left(\frac{MPE_1^2}{3} \right) + \left(\frac{MPE_2^2}{3} \right) + \dots$$

$$u_{MS} = \sqrt{\frac{MPE_1^2}{3} + \frac{MPE_2^2}{3} + \dots}$$

4.8 Minimum Possible Tolerance for Measuring Systems / Measurement Processes

In order to classify measuring systems and measurement processes, it is advisable to calculate the minimum tolerance required to establish the capability of the measuring system and the measurement process. This tolerance is calculated by rearranging the formula and replacing Q_{MS} or Q_{MP} by Q_{MS_max} or Q_{MP_max} . The result will be the minimum possible tolerance for the measuring system $TOL_{MIN-UMS}$ or the measurement process $TOL_{MIN-UMP}$:

$$TOL_{MIN-UMS} = \frac{2 \cdot U_{MS}}{Q_{MS_max}} \cdot 100\%$$

or

$$TOL_{MIN-UMP} = \frac{2 \cdot U_{MP}}{Q_{MP_max}} \cdot 100\%$$

The inspected measurement process can be used down to the minimum tolerance value of $TOL_{MIN-UMP}$.

- Remark 1:** If the minimum tolerance value $TOL_{MIN-UMS}$ for the measuring system is already similar to the specified tolerance TOL , an estimation of the standard uncertainties of the measurement process is unnecessary because the result would exceed the Q_{MP_max} value anyway, unless the uncertainties are negligibly small.
- Remark 2:** This procedure is very useful in case of standard measuring instruments and similar measurement tasks.
- Remark 3:** The calculated minimum tolerance only applies to the respective measurement task.

4.9 Uncertainty Budget

An uncertainty budget gives a clear overview of the capability of measuring systems and measurement processes. Table 5 shows an example of a possible uncertainty budget.

Uncertainty component (name)	Evaluation type	Variation limit a	Coverage factor b	Standard deviation or U_i from ANOVA	Uncertainty component (value)
$u(x_i)$	A/B	<i>Type B evaluation</i>		<i>Type A evaluation</i>	$u(x_i)$
name $u(x_i)$	A				$u(x_i) = S_i$ or U_i from ANOVA
⋮	⋮				⋮
name $u(x_i)$	B				$u(x_i) = a \cdot b$
⋮	⋮			⋮	⋮
Combined measurement uncertainty					$u(y) = \sqrt{\sum_{i=1}^n u(x_i)^2}$
Expanded measurement uncertainty					$U_{MS} = k \cdot u(y)$ $U_{MP} = k \cdot u(y)$

Table 5: Information provided by an uncertainty budget

Every measured quantity value obtained in a measurement in practice includes the expanded measurement uncertainty U_{MP} .

4.10 Capability of the Measurement and Production Processes

Figure 9 displays the relation between observed process capability index ($C_{p,obs}$), the real process capability index ($C_{p,real}$) and the capability ratio (Q_{MP}).

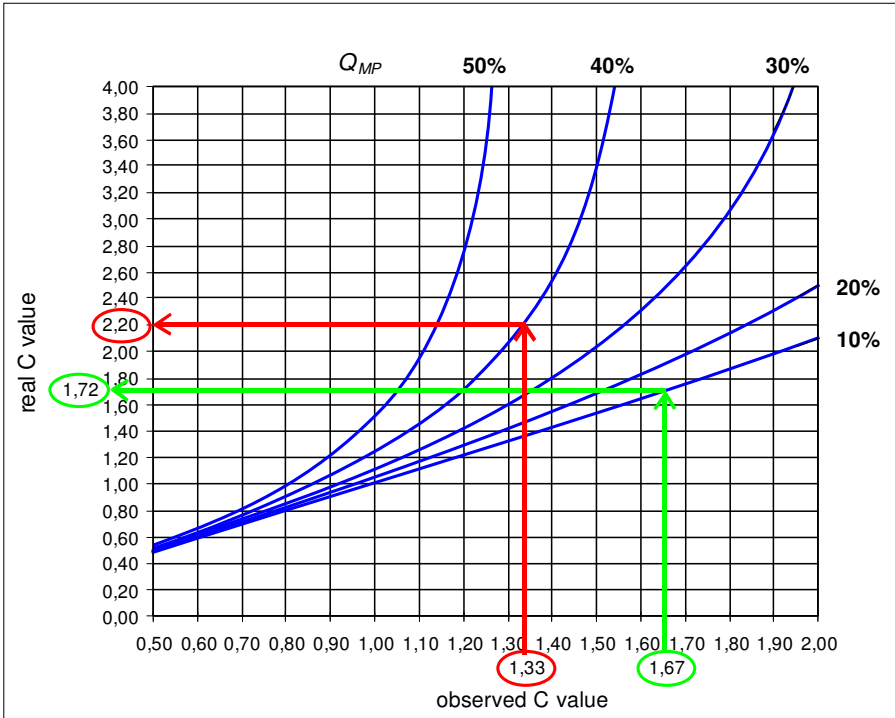

Figure 9: Display of the real C-value as a function of the observed C-value subject to Q_{MP}

The curve shape displayed in Figure 9 shows that a real capability index of 2,21 from an actual production process and a measurement capability figure $Q_{MP} = 40\%$ only results in an observed capability index of 1,33. A capability ratio Q_{MP} of 10% shows to a considerably better result. In this case, an observed C-value of 1,67 corresponds to a real C-value of 1,72.

The calculation is based on the following assumptions:

- Measured quantity values of the manufactured characteristic are normally distributed.
- The calculation of the Cp index is based on 99,73% reference value estimated by 6 standard deviations.
- The observed, empirical standard deviation is: $s_{obs} = \sqrt{s_{real}^2 + s_{MP}^2}$
- The uncertainty range regarding the specification limits is symmetrical.
- The coverage factor used to calculate the combined uncertainty is 2.

Based on the curve shapes (Figure 9), the $C_{p;real}$ and $C_{p;obj}$ values can be specified for typical C-values as a function of Q_{MS} (Table 6).

Observed C-value	Real C-value for the process when...				
	$Q_{MP} = 10\%$	$Q_{MP} = 20\%$	$Q_{MP} = 30\%$	$Q_{MP} = 40\%$	$Q_{MP} = 50\%$
0,67	0,67	0,68	0,70	0,73	0,77
1,00	1,01	1,05	1,12	1,25	1,51
1,33	1,36	1,45	1,66	2,21	18,82
1,67	1,72	1,93	2,53		
2,00	2,10	2,50	4,59		

Table 6: Relation between $C_{p;real}$ and $C_{p;obs}$ for typical C-values

4.11 Dealing with Not Capable Measuring Systems / Measurement Processes

In order to improve a measuring system / measurement process, the standard uncertainties must be reduced, for example,

- by using measurement procedures including a lower measurement uncertainty and
- by reducing the effects of the influence factors affecting the measurement process (see Figure 5).

In addition, it is important to check whether the tolerance zone can be extended.

The application of measurement procedures resulting in a lower measurement uncertainty is a simple solution, however, they must be proved economically optimal for performing the measuring task.

Here are some examples of how to reduce the effects of influence factors on the measurement uncertainty:

Measuring equipment / material measure

- selecting more suitable sensors
- selecting material measures of a higher quality
- selecting a sampling strategy
- optimizing the sampling strategy (e.g. measuring speed, definition of measuring points, mounting device, settings, algorithms for evaluation, sequence)
- repeated measurements including averaging (Annex C)

Test parts

- correcting temperature of a test part to a standard temperature of 20 °C
- cleanliness
- improving dimensional stability and surface properties
- avoiding burrs

Operator

- improving skills and qualifications of operators
- taking measures to raise employee motivation

Environment (temperature, vibrations, etc.)

- avoiding negative influences by selecting proper workstation or screen
- taking measurements under temperature-controlled conditions
- positioning measuring instruments in a place where they are protected against vibrations

Stability of a measuring instrument (stability)

- detecting and correcting components causing a trend

5 Measurement Process Capability Analysis

5.1 Basic Principles

The previous chapters dealt with the following, general topics:

- necessity to determine the expanded measurement uncertainty U_{MS} for a measuring system and U_{MP} for a measurement process
- calculation of the expanded measurement uncertainties U_{MS} and U_{MP} based on the combined measurement uncertainty u_{MS} or u_{MP} and the coverage factor k
- criteria for the capability ratios of measuring systems Q_{MS} and measurement processes Q_{MP}
- schematic approach for proving the capability of a measuring system and measurement process

This chapter explains how to determine the individual uncertainty components $u(x_i)$ either by using the Type B evaluation (see Chapter 4.4) or by experiment (see Type A evaluation, Chapter 4.4). For this purpose, a standardized method is available and recommended covering a large part of measurement uncertainty estimations that occur in practice.

In some cases, where the preconditions set out for this method are not present, the user must use the general current method for determining the measurement uncertainty that is described in the “Guide to the expression of uncertainty in measurement“ (ISO/IEC Guide 98-3 [22]).

If the uncertainty components estimated from an experiment do not correspond to the expected spread of these components in the actual measurement process, then these components must not be estimated experimentally. Instead, they should be derived using a mathematical model (e.g. constant temperature in a measuring laboratory when conducting a test and the normal temperature variations of the place of the future application). In this model, the expected variation in the real measurement process must be considered.

The following chapters, however, are based on the assumption that only the uncertainty components test part homogeneity, resolution and temperature should be derived using a mathematical model.

5.2 Capability Analysis of a Measuring System

In principle, the expanded measurement uncertainty refers to the entire measurement process (see Chapter 4.6). However, since the measuring system is an essential part of the measurement process, it should be evaluated separately. Its capability ratio Q_{MS} (see Chapter 5.2.1) is generally easier to determine than the capability of the measurement process.

Measuring systems require that the resolution (%RE) should be lower than 5% of the specification. If this requirement is not satisfied, a different measuring system has to be applied.

Uncertainty components related to the measuring system are “calibration uncertainty on the reference standard”, “uncertainty from bias,” “uncertainty from measurement repeatability” and “uncertainty from linearity” (see Table 7).

The standard uncertainty due to the calibration on the reference standard is given in the calibration certificate.

If the bias is not compensated by calculation, repeated measurements are taken on one, two or three measurement standards, depending on the measuring system and measurement task. The values of the standards are approximately equidistantly placed throughout the relevant measuring interval associated with the measurement process (see Figure 14). The measured quantity values form the basis of determining the standard uncertainties due to the bias and equipment influences. Before starting the analysis, the working point(s) of the measuring system must be set accordingly. For further information, see Annex E.

If the bias of the measuring system can be corrected, the regression function has to be determined by ANOVA (see Chapter 5.2.2). In this case, repeated measurements are taken on at least three measurement standards whose values are placed throughout the relevant measuring interval (see Figure 14). These measured values are used to calculate the regression function and the compensation is made. In spite of the compensation, some uncertainties are remaining. They are composed of the pure error standard deviation u_{EV} and the lack-of-fit u_{LIN} . Both must be considered in calculating the combined standard uncertainty of the measuring system.

Figure 10 shows a flow chart of the measuring system capability analysis. Table 7 explains how to determine single standard uncertainties. Chapter 4.7 describes how to calculate the capability ratio Q_{MS} or the minimum permissible tolerance $TOL_{MIN-UMS}$.

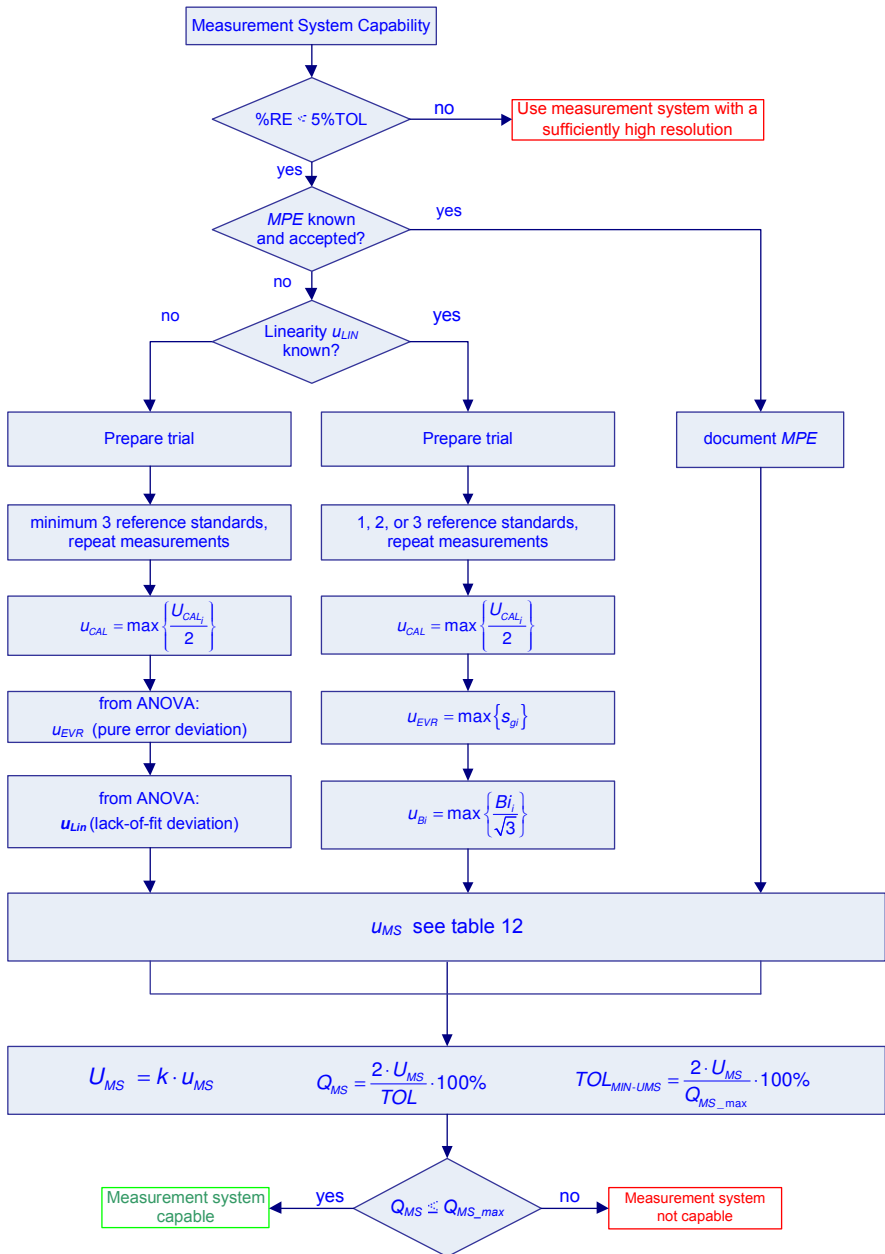

Figure 10: Measuring system capability analysis

Uncertainty components	Symbol	Test / model
Resolution of the measuring system	u_{RE}	%RE must be lower/equal than 5% of the specification $u_{RE} = \frac{1}{\sqrt{3}} \cdot \left(\frac{RE}{2} \right) = \frac{1}{\sqrt{12}} \cdot RE$ where RE is the resolution See note on page 56.
Calibration uncertainty	u_{CAL}	Obtained from the calibration certificate of measurement standards. In cases where the uncertainty in protocol is given as an expanded uncertainty, it should be divided by the corresponding coverage factor: $u_{CAL} = U_{CAL} / k_{CAL}$
Repeatability on reference standard	u_{EVR}	Depending on the measuring system, repeated measurements are taken on one, two or three standards. On one measurement standard, at least 25 repeated measurements are taken whereby their spread $u_{EVR} = s_g$ can be estimated. On each of two standards, at least 15 repeated measurements are taken whereby their spread u_{EVR} can be estimated. The greatest one of the results is used. On each of three standards, at least 10 repeated measurements are taken whereby their spread u_{EVR} can be estimated. The greatest one of the results is used.
Uncertainty from bias	u_{BI}	From the measured values on a reference standard taken during a repeatability analysis, the standard uncertainty u_{BI} can be calculated based on the systematic measurement error from: $u_{BI} = \frac{ \bar{x}_g - x_m }{\sqrt{3}}$ In case of two or three measurement standards, the greatest one of the results is used.
Uncertainty from linearity	u_{LIN}	In the calculation of linearity, u_{LIN} is determined by the method of ANOVA (lack-of-fit deviation / see Annex A.2). For measuring systems with linear material measure, the uncertainty from linearity is determined based on the results from the manufacturer's or calibration certificate.
Uncertainty from other influence components	u_{MS_REST}	Any further influences on the measuring system, supposed or substantial, must be estimated separately by experiments or from tables and manufacturer's specifications.

Table 7: Typical uncertainty components of a measuring system

Remark: The ISO/TS 15530 [16] adds the bias B_i as a whole to the other components in order to calculate the combined standard uncertainty for the measuring system u_{MS} :

$$u_{MS} = \sqrt{(u_{CAL}^2 + u_{EVR}^2)} + B_i$$

It is assumed that B_i is generally small. If the bias is large, it must be corrected on the measuring system. In order not to make a general decision, this document treats the standard uncertainty arising from the bias as any other standard uncertainty component:

$$u_{MS} = \sqrt{(u_{CAL}^2 + u_{EVR}^2 + u_{BI}^2)}$$

In order to make the two formulas comparable, only the u_{CAL} , u_{EVR} and u_{BI} components were observed.

The estimation of each single uncertainty component is not required when the maximum permissible error MPE of the measuring system is known, traceable and documented. In this case, u_{MS} is determined by MPE ($u_{MS} = MPE/\sqrt{3}$). However, calculations referring to characteristics require these estimations.

The following chapters explain how to determine the respective standard uncertainty.

5.2.1 Resolution of the Measuring System

In order to establish the capability of a measuring system, its resolution (see Table 7) must not exceed 5 % of the specification. For this reason, the standard uncertainty arising from the resolution is only considered for measurement processes.

RE is the smallest step (between two scale marks) of an analogue measuring instrument that can be read clearly or the step in last digit of a digital display (e.g. 0,001, 0,5 or 1,0).

5.2.2 Repeatability, Systematic Measurement Error, Linearity

In industrial practice, the reported uncertainty of the measuring system is usually limited to the calibration uncertainty on the used reference standard, the uncertainty from repeatability and from measurement bias.

In order to determine the uncertainty arising from the repeatability on a measurement standard, it is recommended to use the experiment known as a “Type 1 study”, used for determining the measuring system capability indices C_g or C_{gk} (see Chapter 5.2.2.1 and [25]). This study can also be applied to two or three standards.

If the linearity of the measuring system has to be determined, it can be done by means of a linearity study based on at least three reference standards. The result of this investigation (regression function) can then be used for correction of the measurement result which reduces the uncertainty from linearity. (see Chapter 5.2.2.2).

5.2.2.1 Estimating the Systematic Measurement Error and Repeatability according to the “Type 1 Study”

The systematic measurement error (bias) must be reduced as far as possible by adjustment or calculation. Nevertheless, some small or unknown residual systematic errors will remain. The errors are the maximum values of the known systematic measurement errors within the used measuring interval and cannot be corrected. This error can be estimated by an investigation on a measurement standard (material measure). This study can also be applied with several standards.

Repeated measurements on a standard

In order to determine the uncertainty from repeatability and resolution on a reference standard u_{EVR} , it is recommended to use the experiment known as a “Type 1 study” (determining the capability of the measuring system) (see guide to the proof of measuring system capability [25]). However, in this case, the aim of the experiment is the estimation of uncertainty components rather than the estimation of the capability ratio.

The determination of the uncertainty u_{EVR} comes from the standard deviation of the repeatability s_g estimated from measurements on a measurement standard. It should be based on the spread of a minimum of 25 repeated measurements, to estimate the combined effect of bias and repeatability.

$$u_{EVR} = s_g = \sqrt{\frac{1}{K-1} \cdot \sum_{i=1}^K (y_i - \bar{x}_g)^2}$$

where: K number of repeated measurements, normally $K = 25$ or more
 y_i single value of the i -th measurement
 \bar{x}_g the arithmetic mean of all the sample values

The standard uncertainty u_{BI} from bias is calculated from:

$$u_{BI} = \frac{|\bar{X}_g - X_m|}{\sqrt{3}}$$

where: x_m reference quantity value of the measurement standard within the tolerance of the test characteristic and bias Bi

$$Bi = |\bar{X}_g - x_m|$$

The capability indices C_g and C_{gk} used in [26] are calculated from the series of measurements determined thereby:

$$C_g = \frac{0,2 \cdot TOL}{4 \cdot s_g} \quad C_{gk} = \frac{0,1 \cdot TOL - Bi}{2 \cdot s_g}$$

If u_{CAL} and u_{BI} are neglected, Q_{MS} can be compared to C_g . In this case, a C_g -value of 1,33 corresponds to a Q_{MS_max} -value of 15 % (see Chapter 4.7).

Remark: There are several company guidelines using a sample standard deviation of $6s_g$ or $3s_g$ (coverage probability $P = 99,73\%$) instead of $4s_g$ or $2s_g$ ($P = 95,45\%$). In this case, a C_g -value of 1,33 corresponds to a Q_{MS_max} -value of 10% (see Chapter 4.7).

The comparison between the presented determination of standard uncertainties and calculation of capability indices shows that the procedure, in order to obtain measured quantity values, is the same. The difference lies in the derived statistical values:

- u_{EVR} and u_{BI} (measurement uncertainty)
- C_g and C_{gk} (capability of measuring system)

and in the interpretation of results. In this way, available measured quantity values gained in previous capability analyses according to the „Type 1 study“ for determining the standard uncertainties can be used.

Remark: The result of u_{EVR} can be compared to u_{RE} . The greater value of the two is used as the standard uncertainty from repeatability u_{EV} . Reason: Even though the requirement $\%RE \leq 5\%$ is satisfied, it is possible that, for example in case of 25 repeated measurements on a reference standard, the variation may be zero ($u_{EVR} = 0$) or only one value differs in its resolution from the other values of a series of measurements. In this case, it generally applies $u_{EVR} < u_{RE}$.

Example: A diameter of $20 \pm 0,2$ mm is to be inspected. A digital micrometer with a resolution of 0,01 mm ($\%RE = 2,5 \%$) meets the requirement $\%RE \leq 5\%$. If this micrometer performs 25 repeated measurements on a gauge block (20 mm), a value of 20,00 is frequently obtained. This leads to an uncertainty u_{EVR} amounting to zero. In this case, the standard uncertainty from the resolution of the measuring system $u_{RE} = 2,89 \mu\text{m}$ must be used rather than the standard uncertainty from repeatability.

Example on one measurement standard

In this example, a characteristic with a nominal quantity value of 6 mm is used. The upper specification limit is $U = 6,03$ mm and the lower specification limit is $L = 5,97$ mm. This leads to a specification of 0,06 mm.

The uncertainty from linearity is negligibly small ($u_{LIN} = 0$).

The resolution of the used measuring system amounts to 0,001 mm ($\triangleq \%RE = 1,66\%$). Thus, the requirement $\%RE \leq 5\%$ is fulfilled.

The calibration certificate for the reference standard with a reference quantity value of 6,002 mm gives $u_{CAL} = 0,002$ mm and $k_{CAL} = 2$.

In this example, 50 repeated measurements (25 would be sufficient) are performed on the reference standard (see Table 8).

	Standard 1		Standard 1		Standard 1		Standard 1		Standard 1
Trial 1	6,001	Trial 11	6,001	Trial 21	6,002	Trial 31	6,000	Trial 41	6,000
Trial 2	6,002	Trial 12	6,000	Trial 22	6,000	Trial 32	6,001	Trial 42	6,001
Trial 3	6,001	Trial 13	6,001	Trial 23	5,999	Trial 33	6,001	Trial 43	6,002
Trial 4	6,001	Trial 14	6,002	Trial 24	6,002	Trial 34	6,002	Trial 44	6,001
Trial 5	6,002	Trial 15	6,002	Trial 25	6,002	Trial 35	6,001	Trial 45	6,002
Trial 6	6,001	Trial 16	6,002	Trial 26	6,001	Trial 36	6,001	Trial 46	6,002
Trial 7	6,001	Trial 17	6,002	Trial 27	6,001	Trial 37	6,000	Trial 47	6,001
Trial 8	6,000	Trial 18	6,002	Trial 28	6,000	Trial 38	6,000	Trial 48	6,002
Trial 9	5,999	Trial 19	6,002	Trial 29	5,999	Trial 39	5,999	Trial 49	6,001
Trial 10	6,001	Trial 20	6,000	Trial 30	5,999	Trial 40	5,999	Trial 50	6,001

Table 8: Measured values of the repeated measurements on the standard

From these data and measured quantity values, the following standard uncertainties and results of the measuring system are obtained:

Uncertainty components	Symbol	Type	u	Rank
Resolution of the measuring system	u_{RE}	B	0.000289	4*
Calibration uncertainty	u_{CAL}	B	0.00100	1
Repeatability on reference standard	u_{EVR}	A	0.000995	2
Uncertainty from linearity	u_{LIN}	B		
Uncertainty from Bias	u_{BI}	A	0.000635	3
Measurement system	u_{MS}		0.00155	

Figure 11: Standard uncertainties of the measuring system



Tolerance	TOL	=	0.060	
Resolution	%RE	=	1.67%	
Combined standard uncertainty	u_{MS}	=	0.00155	
Expanded measurement uncertainty	U_{MS}	=	0.00309	
Capability ratio limit	Q_{MS_max}	=	15.00%	
Capability ratio	Q_{MS}	=	10.31%	
Minimum tolerance	$TOL_{MIN-U_{MS}}$	=	0.0413	

Figure 12: Results of the measuring system

The measuring system is applicable down to a minimum tolerance of 0,042 mm.

Remark: The results are based on a statistical evaluation whose informational value must be assessed by means of the confidence interval. However, this is not done in this example. Thus, a repetition of the experiment or different sample sizes leads to slightly different results.

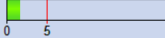
Repeated measurements on two measurement standards

For this analysis, the use of a material measure is recommended whose actual values lie within a range of $\pm 10\%$ around the specification limits (see Figure 13). Before starting the study, the measuring system must be set according to the procedure described in Annex E.

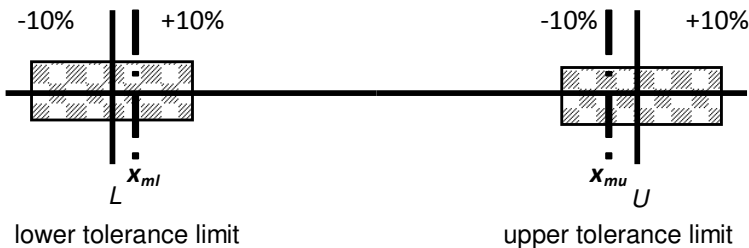

Figure 13: Recommended location of the material measure

x_{ml} actual value of material measure near the lower specification limit L

x_{mu} actual value of material measure near the upper specification limit U

In general, a minimum of 15 repeated measurements should be performed on each measurement standard. Based on these measurement results, u_{EVR} and u_{BI} are estimated for each measurement standard according to the described procedure associated with standards. The greater value of the two serves as the uncertainty component u_{EVR} or u_{BI} .

$$U_{EVR} = \max$$

$$U_{BI} = \max$$

Repeated measurements on three measurement standards

For this simplified linearity analysis, the use of a material measure is recommended whose actual values lie within a range of $\pm 10\%$ around the specification limits (Figure 14).

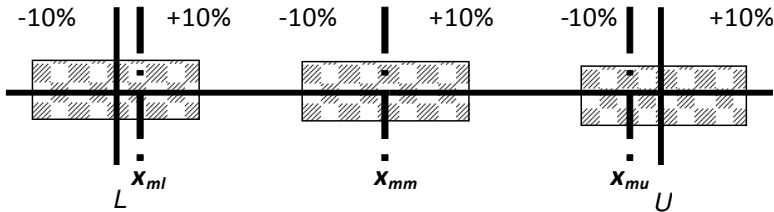

Figure 14: Recommended location of the material measure

x_{ml} actual value of material measure near the lower specification limit L

x_{mm} actual value of material measure near the center of the specification

x_{mu} actual value of material measure near the upper specification limit U

In general, a minimum of 10 repeated measurements should be performed on each measurement standard. Based on these measurement results, u_{EVR} and u_{BI} are estimated for each measurement standard according to the described procedure associated with standards. The greater value serves as the uncertainty component u_{EVR} OR u_{BI} .

$$U_{EVR} = \max. \{u_{EVR1}, u_{EVR2}, u_{EVR3}\}$$

$$U_{BI} = \max. \{u_{BI1}, u_{BI2}, u_{BI3}\}$$

In this case, the standard uncertainty from linearity is part of U_{BI} . This leads to $U_{LIN} = 0$.

5.2.2.2 Linearity Analysis with Correction on the Measuring Instrument

The following procedure is suggested:

- On each of a minimum of three reference standards at least 10 repeated measurements are performed (the number of standards multiplied by the number of repeated measurements must lead to a minimal sample size of 30).
- The reference standards should be evenly spread over the entire specification zone. The areas associated with the specification limits displayed in Figure 13 must be considered.
- A regression analysis is performed in order to estimate the linear regression function by assuming that the pure error standard deviation is constant over the spread of measurement results (see Figure 15 and Annex A.1).
- An analysis of variance is performed whereby residuals are analyzed due to a lack-of-fit and pure error standard deviation (see Figure 15 and Annex A.2).
- Estimation of the uncertainty components based on the results of the method of ANOVA.
- Correction on the measuring system, i.e. correction on future measurements (where appropriate).

Generally, the following preconditions apply:

- The pure error standard deviation (standard deviations from repeated measurements on the standards) is always constant.
- The regression function is linear (regression line).
- The calibration uncertainty on the reference standards is lower than 5 % of the specification.
- The measurements are representative of the future use of the measuring system regarding the environment and other conditions.
- The repeated measurements of the reference standards are independent from each other and the results are normally distributed.
- The values of the standards are approximately equidistantly placed throughout the relevant measuring interval.

Example of a linearity analysis with regression analysis

For a better illustration of this issue, the example includes a high lack-of-fit and a considerable pure error standard deviation. This leads to great uncertainties in the end. Moreover, more than three reference standards are used. This is quite unusual in practice.

In a linearity analysis, 5 repeated measurements ($K=5$) on each of 6 reference standards ($N=6$) are performed. The minimum requirement of a sample size of $N \cdot K = 30$ is satisfied.

The following values (in mm) were determined:

	Standard 1	Standard 2	Standard 3	Standard 4	Standard 5	Standard 6
Reference value	0,000	5,000	10,000	15,000	20,000	30,000
Trial 1	-1,113	1,345	4,978	14,746	20,816	21,843
Trial 2	1,324	3,126	4,083	15,932	21,869	21,177
Trial 3	-2,482	2,123	6,935	17,958	23,095	24,334
Trial 4	1,673	2,587	5,257	18,515	24,224	23,547
Trial 5	-1,876	0,457	5,996	19,359	22,529	24,420

Table 9: Measured quantity values of the analysis

Assuming that the preconditions listed in Chapter 5.2.2.2 are fulfilled, the regression function is calculated from the reference quantity values x_n and the measured quantity values y_{nk} . Annex A.1 contains the formulas for estimating the unknown parameters of the function.

regression function: $\hat{y} = -0,6176 + 0,9183 \cdot x$

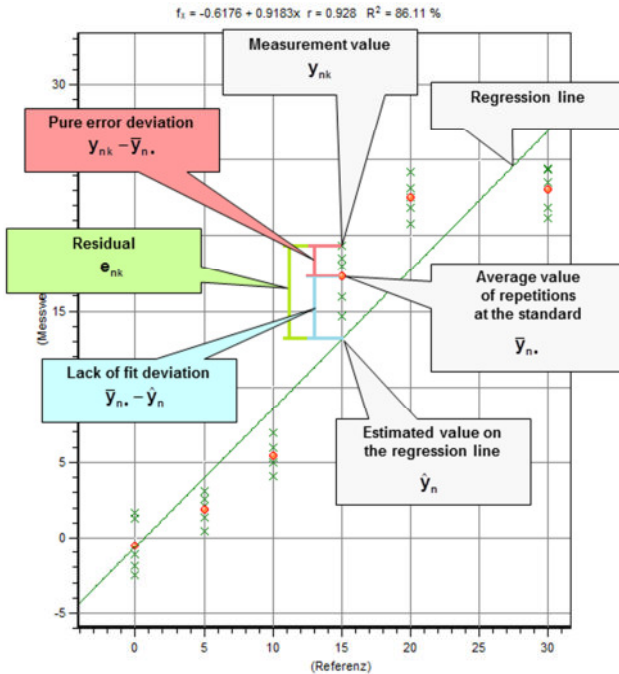

Figure 15: Diagram of an analysis of variance

Figure 15 displays relevant components of the regression function and the analysis of variance and their relation to one another. The diagram gives an initial impression regarding the following information:

- whether the measurement process is under statistical control during the experiment
- correctness of assuming a constant linearity (lack-of-fit)
- deviation of the measured quantity values from the regression line (residuals)
- deviation of the single repeated measurements on a reference standard (pure error standard deviation)
- the presence of outliers that need further investigation

For an evaluation, the residuals e_{nk} can be observed in a value chart (see Figure 16 a)). In order to find out whether the single measurements are independent from one another, the residuals e_{nk} must be normally distributed. This can be seen by b) plotting them on probability plot (see Figure 16). Here, the measured quantity values should adapt to the probability straight line as far as possible. The spread of the residuals e_{nk} can be obtained by c) plotting them on the fitted values \hat{y}_n (see Figure 16).

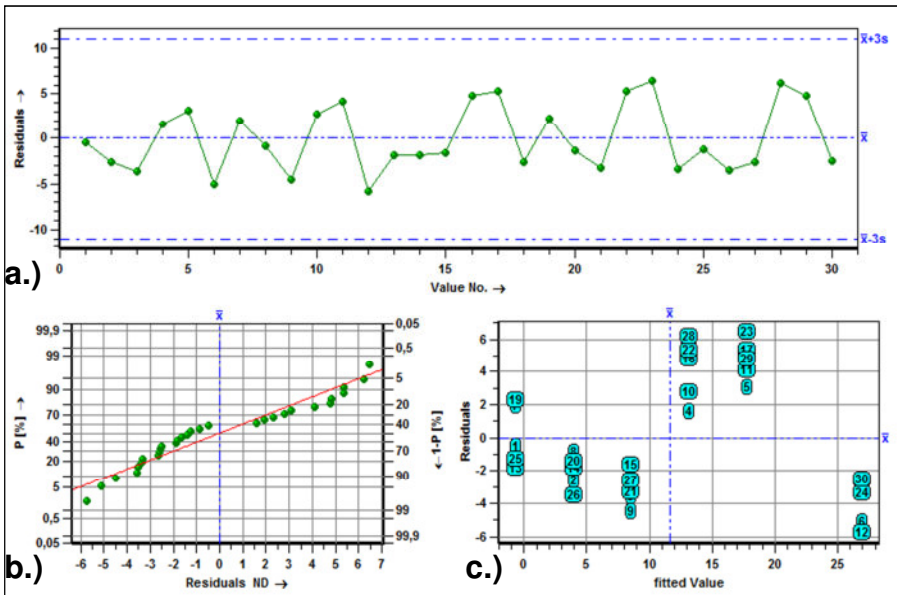

Figure 16: a.) Value chart of the residuals
 b.) Residuals plotted on a probability plot
 c.) Residuals plotted on fitted values

If there are inconsistencies in the graphical display, they must be eliminated. If necessary, the analysis must be repeated.

After the graphical evaluation of the regression function and the residuals, the estimates of the uncertainty components u_{LIN} and u_{EVR} should be calculated by using the method of ANOVA. Annex A.2 provides the required ANOVA table with the associated formulas.

A given calibration uncertainty of $u_{CAL} = 0,05$, a resolution of $RE = 0,001$ mm and a tolerance of $TOL = 30$ mm lead to the following results:

Uncertainty components	Symbol	Type	u	Rank
Resolution of the measuring system	u_{RE}	B	0.000289	4*
Calibration uncertainty	u_{CAL}	B	0.0500	3
Repeatability on reference standard	$u_{EV\overline{R}}$	A	1.488	2
Uncertainty from linearity	u_{LIN}	A	9.266	1
Measurement system	u_{MS}		9.385	

Figure 17: Uncertainty budget of the measuring system



Tolerance	TOL	=	30.000	
Resolution	%RE	=	0.00%	
Combined standard uncertainty	u_{MS}	=	9.385	
Expanded measurement uncertainty	U_{MS}	=	18.77	
Capability ratio limit	Q_{MS_max}	=	15.00%	
Capability ratio	Q_{MS}	=	125.13%	
Minimum tolerance	$TOL_{MIN-U_{MS}}$	=	250.3	

Figure 18: Result for the measuring system

Due to the sharp linearity deviation and repeatability, the measuring system is not qualified for the measurement task. A qualified measuring system requires a minimum tolerance of 251 mm.

5.3 Measurement Process Capability Analysis

In addition to the uncertainty components of the measuring systems described above, further uncertainty components must be determined in order to evaluate the measurement process under real conditions. The procedure displayed in Figure 19 is recommended in order to perform a measurement process capability analysis.

Table 10 and 11 contain the single standard uncertainties and Table 14 explains how to estimate or calculate the respective standard uncertainty.

Table 12 gives an overview of how to calculate the expanded measurement uncertainty of the measuring system U_{MS} and the measurement process U_{MP} . It also contains the capability ratios for the measuring system Q_{MS} and the measurement process Q_{MP} . By comparing these results to a specified limit, it is possible to determine whether the respective measuring system or measurement process is qualified for the intended measurement task.

If the ratio exceeds or goes below the specified limit, the following questions can be answered by rearranging the stated equation.

- Statistic exceeds limit:
 “What is the minimum tolerance demanded in order, just barely, to achieve capability? “
- Statistic goes below limit:
 “What is the maximum tolerance demanded in order, just barely, to achieve capability? “

This requires the calculation of the statistics for the measuring system $TOL_{MIN-UMS}$ and the measurement process $TOL_{MIN-UMP}$.

Uncertainty components	Symbol	Test / model
Repeatability on test parts	u_{EVO}	Minimum sample size: 30 Always a minimum of 2 repeated measurements on a minimum of 3 test parts measured by a minimum of 2 operators (if relevant), measured by a minimum of 2 different measuring systems (if relevant) see “Type 2 study” MSA [1] Estimation of uncertainty components by the method of ANOVA.
Reproducibility of operators	u_{AV}	
Reproducibility of measuring systems (place of measurement)	u_{GV}	
Reproducibility over time	u_{STAB}	
Uncertainty from interaction(s)	u_{IAI}	

Table 10: Typical uncertainty components of the measurement process determined in experiments (Type A evaluation)

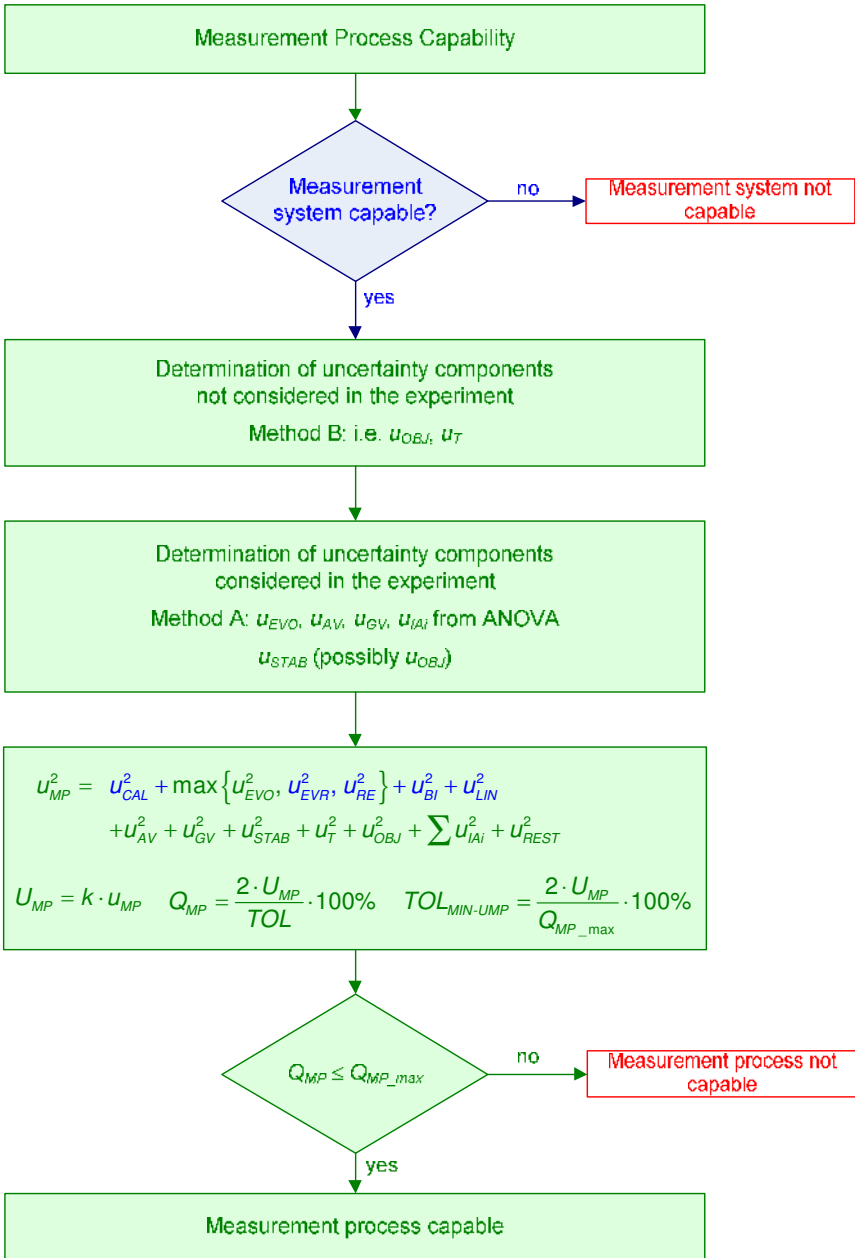

Figure 19: Measurement process capability analysis

Uncertainty components	Symbol	Model
Uncertainty caused by test part non-homogeneity	u_{OBJ}	$u_{OBJ} = \frac{a_{OBJ}}{\sqrt{3}}$ where a_{OBJ} is the maximum form deviation (see Table 14)
Uncertainty caused by temperature	u_T	<p>The influence caused by temperature can be calculated using the formula:</p> $u_T = \sqrt{u_{TD}^2 + u_{TA}^2}$ where u_{TD} uncertainty caused by temperature differences u_{TA} uncertainty caused by expansion coefficients <p>The uncertainty caused by temperature differences could e.g. be estimated in compliance with ISO/TR 14253 Part 2 [15]:</p> $u_{TD} = \Delta T \cdot \alpha \cdot l \cdot \frac{1}{\sqrt{3}}$ where α expansion coefficient ΔT temperature difference l observed value for length measurement <p>If a measuring instrument is set using one reference part and the test part and reference part have different temperatures and expansion coefficients, u_{TD} can be calculated from the difference Δl of the expansion between test part and the working standard:</p> $u_{TD} = \Delta l \cdot \frac{1}{\sqrt{3}}$ <p>The uncertainty on expansion coefficients could e.g. be estimated in compliance with ISO/TR 15530-3 [16]:</p> $u_{TA} = T - 20^\circ C \cdot u_\alpha \cdot l$ where T average temperature during the measurement u_α uncertainty on the coefficient of expansion l observed value for length measurement alternatively: see Annex C1, uncertainty with correction of the different linear expansions see Annex C2, uncertainty without correction of the different linear expansions
Uncertainty caused by other influence components	u_{REST}	Any further influences of the measurement process must be estimated separately.

Table 11: Typical uncertainty components of the measurement process from available information (Type B evaluation)

Table 12 gives an overview of the calculation of the combined measurement uncertainty, the expanded measurement uncertainty and the capability ratios or the minimum tolerance of the measuring system and the measurement process.

Uncertainty components	Symbol	Combined measurement uncertainties	Expanded measurement uncertainties	Capability ratio minimum tolerance
Calibration uncertainty on standard	u_{CAL}	$u_{MS} = \sqrt{u_{CAL}^2 + \max\{u_{EVR}^2, u_{RE}^2\} + u_{BI}^2 + u_{LIN}^2 + u_{MS_REST}^2}$ <p style="text-align: center;">or</p> $\sqrt{\frac{MPE^2}{3}}$ <p style="text-align: center;">or</p> $\sqrt{\frac{MPE_1^2}{3} + \frac{MPE_2^2}{3} \dots}$	$U_{MS} = k \cdot u_{MS}$	$Q_{MS} = \frac{2 \cdot U_{MS}}{TOL} \cdot 100\%$ $T_{MIN-UMS} = \frac{2 \cdot U_{MS}}{Q_{MS_max}} \cdot 100\%$
Uncertainty from bias	u_{BI}			
Uncertainty from linearity	u_{LIN}			
Repeatability on standards	u_{EVR}			
Uncertainty from other influence components (measuring system)	u_{MS_REST}			
Maximum permissible error	MPE			
Repeatability on test part	u_{EVO}	$u_{MP} = \sqrt{u_{CAL}^2 + \max\{u_{EVR}^2, u_{EVO}^2, u_{RE}^2\} + u_{BI}^2 + u_{LIN}^2 + u_{AV}^2 + u_{GV}^2 + u_{STAB}^2 + u_{OBJ}^2 + u_{T}^2 + u_{REST}^2 + \sum_i u_{IA_i}^2}$	$U_{MP} = k \cdot u_{MP}$	$Q_{MP} = \frac{2 \cdot U_{MP}}{TOL} \cdot 100\%$ $T_{MIN-UMP} = \frac{2 \cdot U_{MP}}{Q_{MP_max}} \cdot 100\%$
Reproducibility of operators	u_{AV}			
Reproducibility of measuring systems	u_{GV}			
Reproducibility over time	u_{STAB}			
Uncertainty from interaction(s)	u_{IA_i}			
Uncertainty from test part inhomogeneity	u_{OBJ}			
Resolution of the measuring system	u_{RE}			
Uncertainty from temperature	u_T			
Uncertainty from other influence components	u_{REST}			

Table 12: Calculation of the expanded measurement uncertainty of the measuring system / measurement process and their capability

5.3.1 Example for Determining the Uncertainty Components of the Measurement Process

In order to determine the capability of a measurement process, the standard uncertainties of the measuring system were estimated (see example with one standard in Chapter 5.2.2.1) and an experiment was conducted by 3 operators performing 2 repeated measurements on each of 10 test parts. The results were evaluated by means of the method of ANOVA (see MSA [1]).

Table 13 lists the measured quantity values leading to the standard uncertainties shown in Figure 20 and the results displayed in Figure 21. Since the interactions between operator and part is not significant, pooling is used in the calculation according to the method of ANOVA (see Annex A.2).

	Operator A		Operator B		Operator C	
	Trial 1	Trial 2	Trial 1	Trial 2	Trial 1	Trial 2
1	6,029	6,030	6,033	6,032	6,031	6,030
2	6,019	6,020	6,020	6,019	6,020	6,020
3	6,004	6,003	6,007	6,007	6,010	6,006
4	5,982	5,982	5,985	5,986	5,984	5,984
5	6,009	6,009	6,014	6,014	6,015	6,014
6	5,971	5,972	5,973	5,972	5,975	5,974
7	5,995	5,997	5,997	5,996	5,995	5,994
8	6,014	6,018	6,019	6,015	6,016	6,015
9	5,985	5,987	5,987	5,986	5,987	5,986
10	6,024	6,028	6,029	6,025	6,026	6,025

Table 13: Measured quantity values taken in 2 repeated measurements on 10 parts by 3 operators

Remark:

According to MSA [1], the statistical value $\%GR\&R = \sqrt{EV^2 + AV^2}$ is calculated from the measured quantity values by using the same calculation method of ANOVA. In this case $EV=U_{EVO}$ and $AV=U_{AV}$. This example again shows the similarities between MSA and VDA 5. The difference does not lie in the procedure, but in the different statistics and interpretations.

Uncertainty components	Symbol	Type	u	Rank
Resolution of the measuring system	u_{RE}	B	0.000289	6*
Calibration uncertainty	u_{CAL}	B	0.00100	2
Repeatability on reference standard	u_{EVR}	A	0.000995	3*
Uncertainty from linearity	u_{LIN}	B		
Uncertainty from Bias	u_{BI}	A	0.000635	5
Measurement system	u_{MS}		0.00155	
Reproducibility of operators	u_{AV}	A	0.000932	4
Repeatability on test parts	u_{EVO}	A	0.00153	1
Uncertainty from interactions	u_{AI}	A	[pooling]	
Measurement process	u_{MP}		0.00215	

Figure 20: Standard uncertainties of the measurement process

Combined standard uncertainty	u_{MP}	=	0.00215	
Expanded measurement uncertainty	U_{MP}	=	0.00430	
Capability ratio limit	Q_{MP_max}	=	30.00%	
Capability ratio	Q_{MP}	=	14.34%	
Minimum tolerance	$TOL_{MIN-UMP}$	=	0.0287	

Figure 21: Results of the measurement process

The measurement process is applicable down to a minimum tolerance of 0,03 mm (rounded figure).

6 Ongoing Review of the Measurement Process Capability

6.1 General Review of the Measurement Stability

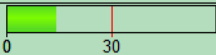
The short-term as well as the long-term stability has to be taken into account when the capability of the measurement process is calculated. However, a change in bias caused by drift, unintentional damage or new additional uncertainty components, which were not known by the time of calculation of the capability, can change the bias in the measurement process over time so that capability is not established anymore. A control chart should be used to be able to determine those possible significant changes in the measurement process. The following sequence is recommended:

Step 1:

Select an appropriate reference standard (working standard) or calibrated work piece with a known value for the test characteristic.

Step 2:

Carry out regular measurements on the reference standard (working standard) or test part (e.g. every day in a working week or at the beginning / end of a shift or prior to each measurement in case of a measurement process used only rarely).

Step 3:

Plot the measured values on a control chart.

Remark: The action limits, are calculated in accordance with known methods of quality control charting techniques.

Step 4:

Case 1 If no out of control signal is detected, it is assumed that the measurement process has not changed significantly.

Case 2 If an out of control signal is detected, the measurement process is assumed to have changed and shall be reviewed.

With this approach, the measurement process is continuously monitored and significant changes can be detected. The resulting knowledge about the measurement process can be taken into account when determining the qualification interval for calibration.

6.2 Correcting the Regression Function

If there was doubt about the linearity of the measuring system during the calculation and if a regression function has been experimentally determined, the method given here can be used for the ongoing review of the linearity of the measuring system. A control chart gives a signal when the regression function needs to be updated.

Flow Chart

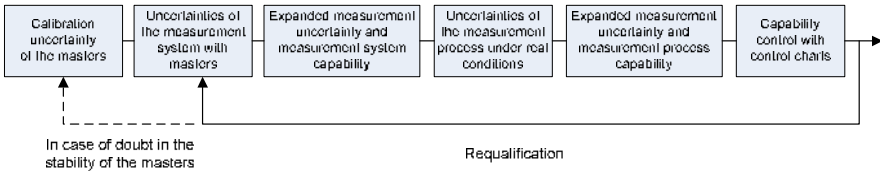

Step 1: Calculating control limits with figures found in Chapter 5.2.2.2

upper control limit:
$$UCL = \frac{\hat{\sigma}}{\hat{\beta}_1} \cdot t_{(1-\frac{\alpha}{2}, m)} \cdot (N \cdot K - 2)$$

lower control limit:
$$LCL = -\frac{\hat{\sigma}}{\hat{\beta}_1} \cdot t_{(1-\frac{\alpha}{2}, m)} \cdot (N \cdot K - 2)$$

Step 2: Selecting the m reference standards

The reference standards (minimum 2) must be chosen in a way that their nominal values cover the range of observations that occur under the actual production conditions.

Step 3: Repeating measurements on the reference standards

For example, the reference standards should be measured every day in a working week.

Step 4: Transforming the p measurement values on the m standards

The p values of the m standards are transformed with the help of the regression function:

$$x = \frac{y - \beta_0}{\beta_1}$$

Then each of the differences between the "true" and the transformed values is calculated.

Step 5: Plotting the differences on a control chart

The differences calculated in Step 4 are plotted on the time axis.

Step 6: Deciding the validity of the regression function

This decision will depend on whether all the differences of all standards are within the control limits.

7 Practical Guidance to Determining Typical Standard Uncertainties

Table 14 gives notes and suggestions together with the associated references about how to determine the standard uncertainties from the respective influence factor.

Source of uncertainty	Suggestions / remarks	Type A/B	Reference
Resolution of the measuring system U_{RE}	<p>RE= is the smallest step (between two scale marks) of an analogue measuring instrument or the step in last digit (e.g. 0,1/0,5/1,0) of a digital display. The resolution should be much lower than the specification interval for the test part to be measured (e.g. %RE ≤ 5% of the specification interval). In this case, the resolution is included in the repeatability.</p> <p>Calculate the standard uncertainty from resolution using the formula:</p> $U_{RE} = \frac{1}{\sqrt{3}} \cdot \left(\frac{RE}{2} \right) = \frac{1}{\sqrt{12}} \cdot RE$	B	Reading / estimations or manufacturer's specification
Calibration uncertainty on the standard u_{CAL}	<p>In metrology, a coverage factor of $k=2$ is typically used in calculations. The standard uncertainty u_{CAL} is calculated by dividing the expanded uncertainty U_{CAL} by the coverage factor 2. The respective K-value is taken from the calibration certificate.</p> <p>Remark</p> <p>The calibration uncertainty shall be much lower than the expected measurement uncertainty.</p>	B	Calibration certificate / manufacturer's specification / internal calibration

Source of uncertainty	Suggestions / notes	Type A/B	Reference
Uncertainty from linearity u_{LIN}	<p><u>Case 1</u> <u>Using manufacturer's specification</u> Where value a is specified by the manufacturer: $u_{LIN} = 1/\sqrt{3} \cdot a$</p>	B	Manufacturer's specification
	<p><u>Case 2</u> <u>Measurement on 3 reference standards</u> Always a minimum of 10 repeated measurements on each of 3 reference standards. Minimum sample size of 30. Standards must be clamped, released, and always measured in the same place of measurement.</p>	A	Experiment with three standards see Annex E
	<p><u>Case 3</u> <u>Measurement on three or more reference standards (regression function)</u> In order to apply this method, the regression function must be considered in the calculations performed by the measurement software. The evaluation of u_{LIN} based on this method only provides the corrected values that are not taken into account on the measuring system.</p>	A	Experiment with standards see Chapter 5
Reproducibility of operators (operator influence) using test parts u_{AV}	<p>Always 2 repeated measurements on each of 10 test parts by 2 or 3 operators <u>Special case:</u> If less than 10 test parts are available, a minimum of 2 repeated measurements on a minimum of 3 test parts by 2-3 operators is required. Remark The test parts used in the experiment should be evenly spread over the entire tolerance zone. Test parts must be clamped, released, and always measured in the same place of measurement. Sequence for repeated measurements: Measure test parts 1 - n and repeat these measurements. In case of the series of measurements, the single operators must not remember the results of the previous measurement.</p> <p>Determine u_{AV} using the method of ANOVA.</p>	A	Experiment Type 2 study [1], [25]

Source of uncertainty	Suggestions / remarks	Type A/B	Reference
Repeatability on test parts without operator influence u_{EVO}	<p>Always 2 repeated measurements on each of 25 test parts.</p> <p>Application in (semi-)automated measuring systems or whenever the operator does not affect the measurement result.</p> <p>Remark The test parts used in the experiment should be evenly spread over the entire tolerance zone. Test parts must be clamped, released, and always measured in the same place of measurement. Sequence for repeated measurements: Measure test parts 1 - n and repeat these measurements.</p> <p>In case of the series of measurements, the single operators must not remember the results of the previous measurement. The result includes the mutual interaction between test part, measuring system, etc.</p>	A	Experiment Type 3 study [25]
Reproducibility of the equal measuring systems (place of measurement) u_{GV}	<p>Relevant to min. 2 measuring systems</p> <p>Evaluation <u>The following generally applies to standards:</u> Observe the variation per place of measurement Compare the measured quantity value \bar{x} to the calibrated values (bias) Observe max – min of the measured quantity values \bar{x} for the single equal measuring systems</p> <p><u>The following generally applies to test parts:</u> Observe the variation per place of measurement Observe max – min of the measured quantity values \bar{x} or the measured individuals x_i per test part for each equal measuring system.</p> <p>The result includes the mutual interaction between test part, measuring system, etc.</p> <p>The experimentally determined uncertainty components are considered by using the analysis of variance (ANOVA).</p> <p>Remark Make this evaluation by using the same working standards and test parts. Clamp, release and measure in the same place of measurement the test parts of the 2 - n measuring systems.</p>	A	Experiment Type 1 and Type 3 study [25]

Source of uncertainty	Suggestions / remarks	Type A/B	Reference
Reproducibility over time u_{STAB}	<p><u>Short-term analysis</u> In general, a short-term analysis does not inspect the stability of the measuring device.</p> <p><u>Long-term analysis</u> If measurement results are assumed to change over time in an initial or basic sampling, the uncertainty should be determined by means of specified series of measurements.</p> <p><u>Ongoing review of the measurement process capability (stability)</u> For an ongoing review of critical characteristics or measurement processes.</p> <p>Remarks Working standards or test parts can be inspected. The values are plotted, for example, on a control chart and the monitoring of measurement process is based on action limits. In case of an action limit violation, U_{MP} must be corrected.</p>	A	Experiments Type 1 study and Type 2 or Type 3 study [25] (see Chapter 6.2)
Form deviation / surface texture / material property of the test part u_{OBJ} (uncertainty from test part inhomogeneity)	<p>There are different methods in order to determine the standard uncertainty from form deviation:</p> <p>information from drawings (maximum permissible form deviation) control chart of series production (actual form deviation) test part inspected in experiment (actual form deviation)</p> <p>The test parts (min. 5) used in the experiment shall be evenly spread over the entire tolerance zone and represent the expected form deviation.</p> <p>Any further properties, supposed or substantial, must be estimated separately by experiments or from tables and manufacturer's specifications.</p>	B B A	Drawing control chart Experiment Table book material data sheet
Uncertainty from temperature u_T	<p>In order to determine the uncertainty from temperature, consider whether a compensation for temperature difference is made.</p> <p>Independent of compensation or complex relations including unknown expansion coefficients, the actual expansion properties should be determined experimentally. Heat the reference standards and test parts and inspect them while they are cooling.</p> <p>The difference a between <i>max</i> and <i>min</i> value is used in order to estimate u_T.</p>	A/B	Experiment See Annex B

Uncertainty from other influence components U_{REST}	Any further influences, supposed or substantial, must be estimated separately by experiments or from tables and manufacturer's specifications.	A/B	Experiment various documents
--	--	-----	------------------------------

Table 14: Methods recommended in order to determine uncertainty components

7.1 Overview of Typical Measurement Process Models

Many measurement processes are only affected by some or very few uncertainty components. For this reason, measurement process models can be defined based on equal uncertainty components (see Table 15).

This overview provides help with the following questions:

- What was the calibration uncertainty used in order to determine the actual value of the reference standard?
- Can the purchased measuring equipment be accepted / approved for use?
- What are the uncertainty components to be considered with standard measuring systems?
- Are the measuring system (measuring instrument) and measuring equipment qualified for the respective specification(s)? How much do the production parts affect the measurement result or the capability of the measurement process?
- What is the maximum variation of the measured quantity value?
- Which factors must be considered in proving conformance or non-conformance (measurement result within or beyond the specification)?

Remark: Models C, D and E (see Table 15) can be applied separately or are based on one another, i.e. the estimated uncertainties of model C can be transferred to model D or model E. They do not need to be determined once again.

	1 Display resolution U_{FE}	2 Calibration uncertainty U_{CAL} or error limits MPE	3 Setting uncertainty U_{BI} or Bias	4 Repeatability with master(s) U_{EVR}	5 Linearity with master(s) U_{LIN}	6 Reproducibility of the operator with serial parts U_{AV}	7 Repeatability without operator influence with serial parts U_{EVO}	8 Reproducibility of equal measurement systems (measuring points) U_{AV}	9 Reproducibility at different points in time U_{Stab}	10 Form deviation/ surfaces - material attribute measurement objects U_{OBJ}	11 Temperature U_T	12 Other influences U_{Rest}
Model A Calibration uncertainty of the reference	Green	Green	Yellow	Green	Yellow	Gray	Gray	Yellow	Green	Green	Green	Yellow
Model B Acceptance study of the measurement process for standard measurement systems	Green	Green	Yellow	Gray	Yellow	Gray	Yellow	Yellow	Gray	Yellow	Yellow	Yellow
Model C Acceptance study of measurement systems	Green	Green	Green	Green	Yellow	Gray	Yellow	Yellow	Gray	Yellow	Yellow	Yellow
Model D1 Acceptance study of the measurement process with user influence without serial part influence (measure serial parts location oriented)	Green	Green	Green	Green	Yellow	Green	Gray	Yellow	Yellow	Green	Green	Yellow
Model D2 Acceptance study of the measurement process without user influence without serial part influence (serial parts fed semi / automatically)	Green	Green	Green	Green	Yellow	Gray	Yellow	Yellow	Gray	Green	Green	Yellow
Model E1 Conformity / acceptance study of the measurement process with user influence with serial part influence	Green	Green	Green	Green	Yellow	Green	Gray	Yellow	Yellow	Green	Green	Yellow
Model E2 Conformity / acceptance study of the measurement process without user influence with serial part influence (serial parts fed semi / automatically)	Green	Green	Green	Green	Yellow	Gray	Yellow	Yellow	Yellow	Green	Green	Yellow
	Measurement system					Measurement process						

green = always considered
yellow = considered, if available
gray = not considered for this model

Table 15: Typical measurement process models and their uncertainty components

8 Special Measurement Processes

8.1 Measurement Process with Small Tolerances

Small tolerance is not a standardized term but it expresses that the tolerance is very small compared to normal conditions. Characteristic of small tolerances is that they are very hard to create and to measure. For this reason, the usual capability indices and ratios cannot be reached in the same way as those of normal tolerances. They often require conditions that are at the limits of what is physically and technically possible.

Small geometric elements

A small geometric element refers to very small measurement geometries available in a measurement. Only few data points can be recorded for a safe evaluation. Examples are measurements of very short lengths, measurements of very small radiuses or angular measurements where the legs of the angles are very short.

In addition, the point of origin and the end point of the respective geometric element are often not clearly defined. This makes the situation even more difficult. Due to an uneven surface texture, the element does not have an ideal shape and thus, a higher measurement error must be expected.

In individual cases, limits must be determined other than those mentioned in Chapter 4.8.

Remark: It is not possible to determine a limit that generally applies to small tolerances because the limits also depend on the geometry and the physical and technical conditions in terms of the respective measurement task.

8.2 Classification

In production processes including a high production variation, critical characteristics are often classified by dividing the tolerances of the relevant characteristics into two or more classes. Typical fields of application are:

- cylinder and piston
- cylinder and piston pin
- engine block and crankshaft

The classification includes a 100% inspection of the relevant characteristics, the allocation of the parts to the respective class and a corresponding identification.

The measurement uncertainty leads to different classifications, e.g. between manufacturer and customer, for results near the class limits obtained in repeated measurements.

In order to ensure that the same parts can be assigned to a maximum of two adjacent classes in repeated measurements, the expanded measurement uncertainty is permitted to amount to a maximum of half the class width (KB): $U_{MP} / KB \leq 0,5$

In general: The maximum number of adjacent classes one part can be assigned to $2 \cdot U_{MP} / KB + 1 =$ maximum number of adjacent classes.

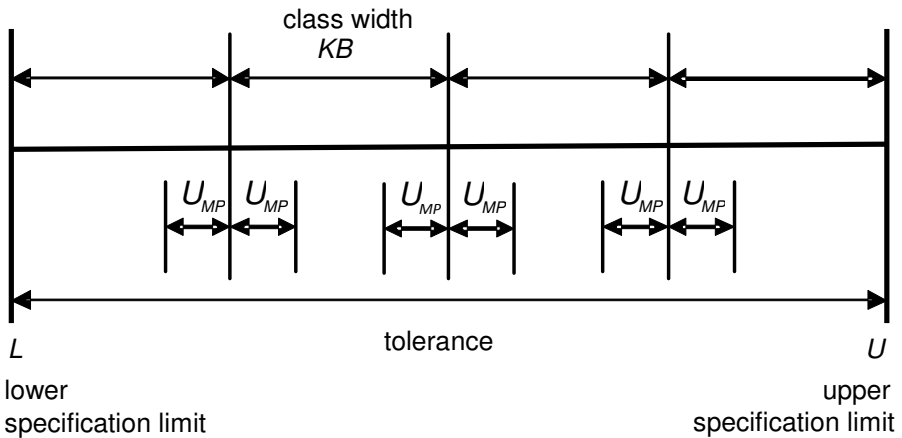

Figure 22: Classification model

8.3 Validation of Measurement Software

Current measuring instrument technologies use software applications in order to determine measured quantity values. The results provided by computer programs are not to be trusted blindly. Their diversity and complexity frequently make such computer programs error-prone. Even comprehensive tests conducted by the manufacturer cannot offer a guarantee that all “errors” have been found. Therefore, it is even more important to validate the

software in order to prove that it meets the demands for the application in practice and that all relevant information is displayed completely.

In order that software applications provide a very high level of correct results, several standards demand validation of the applied software:

- **Extract from DIN EN ISO 9001 [11] or ISO/TS 16949 [23]**

- **Chapter 7.6 “Control of monitoring and measuring equipment”**

- *By using computer software for monitoring and measuring specified requirements, the suitability of this software for the intended use must be confirmed. This confirmation must be provided prior to initial use and, where necessary, repeated later on.*

- **Extract from ISO 10012 [12], Chapter 6.2.2 “Software”:**

- *Software used in the measurement processes and calculations of results shall be documented, identified and controlled to ensure suitability for continued use. Software, and any revision to it, shall be tested and/or validated prior to initial use, approved for use and archived.*

The typical range of the various computer programs used for monitoring and measuring specified requirements include measurement and evaluation programs for:

- coordinate measuring machines
- measuring forms and surfaces
- measuring systems / SPC systems
- test benches
- statistical evaluations

The demands on computer programs apply to third-party software and to the corporate software. A standardized procedure is recommended for an efficient validation. The validation shall be documented by means of an individual checklist. This list shall contain a reference to the following tasks, for example:

- Compare release number on data storage medium to manual / information.
- Document individual configuration and settings of the software.
- Check important functions (to be specified for each respective application) after installation is completed.

- Take measurements on calibrated reference standards and compare results to the calculated actual values and to the results of the previous version (also considering measurement uncertainty).
- Check whether all relevant information is provided.
- Compare results (e.g. obtained from multiple point measuring instrument) with more precise measuring system (e.g. coordinate measuring machine in measuring laboratory).
- In order to make an evaluation, test data shall be provided with known results. This data is loaded, recalculated and the results are compared to the results of references.

After completing the validation successfully:

- approve the program explicitly for use.
- Replace/update all installed systems concerned (if possible via network in order not to miss any individual system).
- inform the users concerned about the latest software version.
- sign a software maintenance contract, if possible, in order to be informed about any future upgrades (e.g. new guidelines, standards and legal regulations) automatically.

Naturally, software is not subject to wear. For this reason, no further inspections of the validated software are required while it is used. However, the software must be validated again when changes in the system environment or to any significant characteristics of the software, hardware or the operating system take place.

Ideally, the software producer / supplier provides a certificate of qualification (expert opinion).

9 Capability Analysis of Attribute Measurement Processes

9.1 Introduction

Because of the nature of attributive measurements, it is only possible to obtain a satisfactory outcome regarding the capability of attribute measurement processes with a great deal of effort.

A suitable approach for calculating the capability of attribute measurement processes must take into account that the probability of a particular test result is dependent on the type of characteristic. Hence, it is all about conditional probabilities.

P (test result | value of the characteristic)

The probability of a correct test result is nearly 100% for the values of the characteristic that lie beyond the areas of uncertainty around the specification limits. This probability is approximately 50% if the measurement results lie in the middle of the uncertainty range ("a decision by pure chance").

In principle, the proposed approach makes a distinction between the calculation of measurement capability without, or with reference values. In the case that reference values are available, a two-step approach is proposed.

9.2 Capability Calculations without Using Reference Values

In this case, only a test of whether there are significant differences between operators can be made. But an assessment of whether the test has led to the correct result cannot be taken. However, this fact must always be considered when no reference values are present.

The choice of test parts may have a decisive influence on the outcome of this test method, but it cannot be taken into account in this case.

The following standard experiment is proposed:

At least 40 different test parts should be tested 3 times by 2 different operators, called A and B. Each of the different measurement results on the 40 parts, which the operator A or operator B has achieved, is assigned to one of the following three classes.

- Class 1: All three test results on the same part gave the result "good".
- Class 2: The three test results on the same part gave different results.
- Class 3: All three test results on the same part gave the result "bad".

The test results can be summarized in a table.

Frequency n_{ij}		Operator B		
		Class 1 result "+++"	Class 2 different results	Class 3 result "---"
Operator A	Class 1 result "+++"	7	3	1
	Class 2 different results	10	4	7
	Class 3 result "---"	2	1	5

This table is now tested using a Bowker-Test of symmetry.

If there are no significant differences between operators, the resulting frequencies n_{ij} in the above table will be sufficiently symmetrical with respect to the main diagonal.

The hypothesis $H_0: m_{ij} = m_{ji}$ ($i, j = 1, \dots, 3$ where $i \neq j$) says that the expected frequencies m_{ij} which lie symmetrical with respect to the main diagonal are identical.

The test value
$$\chi^2 = \sum_{i>j} \frac{(n_{ij} - n_{ji})^2}{n_{ij} + n_{ji}} = 8,603$$

is compared to the test statistic with 3 degrees of freedom.

The hypothesis on symmetry is rejected on the level if the test value is greater than the quantile in the χ^2 distribution with 3 degrees of freedom.

Bowker-Test of symmetry of the expected frequencies		
Null hypothesis H_0 :	$m_{ij} = m_{ji}$ ($i, j = 1, \dots, 3$ where $i \neq j$) both operators obtain similar results	
Alternate hypothesis H_1 :	$m_{ij} \neq m_{ji}$ both operators obtain different results	
Test value:	$\chi^2 = \sum_{i>j} \frac{(n_{ij} - n_{ji})^2}{n_{ij} + n_{ji}} = 8,603$	
Test statistic:	$1-\alpha$ fractile	$\chi^2_{1-\alpha; 3}$ quantile
	-----	-----
	0,90	6,251
	0,95	7,815
	0,99	11,345
	0,999	16,266
Test decision:	The null hypothesis H_0 is rejected with an error probability of $\alpha \leq 5\%$ because the calculated test value is greater than the test statistic, which is the 95 % fractile of the distribution.	
Conclusion: The results of the two operators can be regarded as different.		

In principle, this method is also to be used with more than 2 operators. In such cases, all operators take 3 repeatability tests on the test part and subsequently, all combinations of two combinations of operators should be tested individually. One should note that in this case the significance level is changed for the overall statements by these multiple tests.

9.3 Capability Calculations Using Reference Values

9.3.1 Calculation of the Uncertainty Range

The signal detection approach requires test parts with known reference values.

The purpose of the method is to determine the uncertainty range, in which an operator is unable to make an unambiguous decision. The following numeric example is taken from the MSA manual [1] where two further methods are explained that are not examined in this document.

n	Ref. μ	x_{A1}	x_{A2}	x_{A3}	x_{B1}	x_{B2}	x_{B3}	x_{C1}	x_{C2}	x_{C3}	
25	0,599581										⊖
48	0,587893										⊖
3	0,578495										⊖
5	0,570360										⊖
42	0,568575										⊖
4	0,566152										⊖
35	0,561457										⊖
12	0,559918										⊖
26	0,547204	+									⊖
22	0,545604		+								⊖
6	0,544951			+							⊖
36	0,543077				+						⊖
13	0,542704	+									⊖
16	0,531939	+	+								⊖
23	0,529065			+							⊖
29	0,523754				+						⊖
28	0,521642					+					⊖
19	0,520496						+				⊖
17	0,519694							+			⊖
15	0,517377								+		⊖
10	0,515573									+	⊖
24	0,514192										⊖
41	0,513779										⊖
2	0,509015	+									⊖
32	0,505950	+									⊖
31	0,503091	+									⊖
27	0,502436	+									⊖
8	0,502295	+									⊖
40	0,501132	+									⊖
35	0,498698	+									⊖
46	0,493441	+									⊖
11	0,489905	+									⊖
38	0,488164	+									⊖
33	0,487613	+									⊖
47	0,486379	+									⊖
18	0,484167	+									⊖
49	0,483803	+									⊖
20	0,477236	+									⊖
1	0,476901	+									⊖
44	0,470832	+									⊖
7	0,465454	+									⊖
43	0,462410	+									⊖
14	0,454518	+									⊖
21	0,452310	+									⊖
34	0,449696	+									⊖
50	0,446687	+									⊖
9	0,437617										⊖
39	0,427687										⊖
45	0,412453										⊖
37	0,409238										⊖

for the last time corresponding „Rejection“

for the first time corresponding „Acceptance“

for the last time corresponding „Acceptance“

for the first time corresponding „Rejection“

$d_1 = 0,566152 - 0,542704$
= 0,023448

$d_2 = 0,470832 - 0,446697$
= 0,024135

Symbols

In the table, the reference measurement values are introduced in the form of a code. A plus sign means that all three operators have indicated the result from the test part as approved in all three tests, and that this assessment is consistent with the reference value.

A minus sign means that all three operators have indicated the result from the test part as not approved in all three tests and that this assessment is consistent with the reference value.

The symbol "X" indicates a case where at least one of the operators has come to a test result, which is not consistent with the reference value.

Working steps for determining the uncertainty range:

Step 1:

Sort the table according to the measured reference size. In the above example, a sorting in descending order is made - from the highest reference value descending to the lowest reference value.

Step 2:

Select the last reference value for which all operators have assessed all the results as being unsatisfactory (symbol "-"). This is the transition from symbol "-" to symbol "X".

0,566152	-
0,561457	X

Step 3:

Select the first reference value for which all operators the first time assessed all results being approved (symbol "+"). This is the transition from symbol "X" to the symbol "+".

0,543077	X
0,542704	+

Step 4:

Select the last reference value for which all operators last time assessed all the results as being approved (symbol "+"). This is the transition from the "+" symbol to the symbol "X".

0,470832	+
0,465454	X

Step 5:

Select the first reference value for which every operator has again first assessed all the results as unsatisfactory (symbol "-"). This is the transition from symbol "X" to the symbol "-".

0,449696	X
0,446697	-

Step 6:

Calculate the d_U interval from the last reference value, for which all operators have assessed the result as unsatisfied to the first reference value, for which all operators have the result as approved.

$$d_U = 0,566152 - 0,542704 = 0,023448$$

Step 7:

Calculate the d_L interval from the last reference value, for which all operators have assessed the result as approved to the first reference value, for which all operators have the result as unsatisfied.

$$d_L = 0,470832 - 0,446697 = 0,024135$$

Step 8:

Calculate the average d of the two intervals.

$$d = (d_U + d_L) / 2 = (0,023448 + 0,024135) / 2 = 0,0237915$$

Step 9:

Calculate the uncertainty range.

$$U_{ATTR} = d / 2 = 0,0237915 / 2$$

$$Q_{ATTR} = 2 \cdot U_{ATTR} / TOL = 2 \cdot (0,0237915 / 2) / 0,1 \approx 0,24$$

Then Q_{ATTR} amounts to about 24 %.

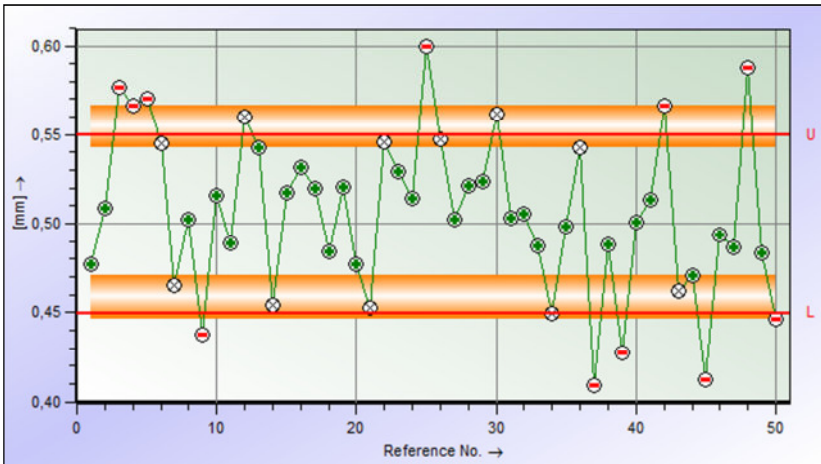

Figure 23: Value chart plotting all reference values and the calculated uncertainty range

Remark: The effort for this method is considerable, as in this example in addition to the 50 reference measurements also at least 450 other test measurements have to be made and documented.

For the selection of test parts, it must be presumed that the uncertainty range will be covered. A maximum of the half tolerance must be covered around the specification limits. This region can be limited due to available information and by considering the resolution. A measurement process capability analysis requires that the limits of the real uncertainty range are determined.

9.3.2 Ongoing Review

For ongoing review of the measurement process, at least one operator should measure at least 3 test parts all with defined reference values.

The test parts should be selected in a way that the reference values are located within the zone I, II or III so that a clear result can be expected (all tests are consistent with the reference value).

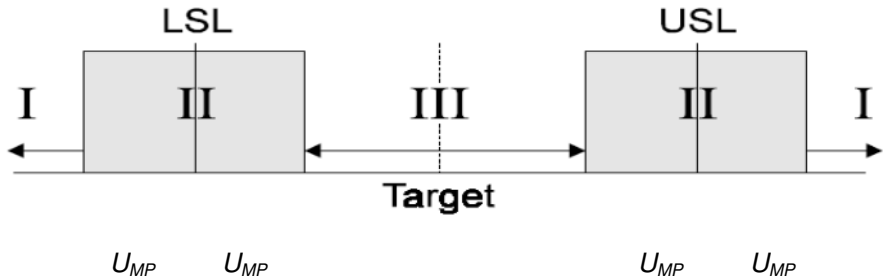

The size of the uncertainty range can either be determined experimentally (see previous chapter), or derived from the actual defined requirements for an appropriate measurement process (Q_{MP}).

$$Q_{MP} = \frac{2 U_{MP}}{TOL} \cdot 100\% \leq Q_{MP_max}$$

This leads to

$$U_{MP_max} = \frac{Q_{MP_max} \cdot TOL}{2 \cdot 100\%}$$

It is to be taken into account that the extended uncertainty is usually given to be the 95,45 % level.

10 Appendix

Annex A Statistical Background of the Measurement Process Capability Analysis

Annex A.1 Formulas for Calculating the Regression Function

$$y_{nk} = \beta_0 + \beta_1 \cdot x_n + \varepsilon_{nk}$$

Formulas for estimating the unknown parameters β_0 ("y-intercept") and β_1 ("slope"):

$$\hat{\beta}_1 = \frac{\sum_{n=1}^N (x_n - \bar{x}) \cdot (y_n - \bar{y})}{\sum_{n=1}^N (x_n - \bar{x})^2}$$

$$\hat{\beta}_0 = \bar{y} - \hat{\beta}_1 \cdot \bar{x}$$

and the residuals e_{nk} :

$$\hat{\sigma}^2 = \frac{\sum_{n=1}^N \sum_{k=1}^K (e_{nk})^2}{N \cdot K - 2} = \frac{\sum_{n=1}^N \sum_{k=1}^K (y_{nk} - \hat{y}_n)^2}{N \cdot K - 2} \quad \text{where} \quad \hat{y}_n = \hat{\beta}_0 + \hat{\beta}_1 \cdot x_n$$

where y_{nk} k^{th} of K measurements on the n^{th} of N standards

x_n conventional true value for the n^{th} standard

ε_{nk} $N(0, \sigma^2)$ distributed deviations of y_{nk} from the expected value $(\beta_0 + \beta_1 \cdot x_n)$ obtained in the measurement on the n^{th} standard

Annex A.2 ANOVA Tables

Since the uncertainty components affect the measurement results in the form of random errors (see Chapter 4.1), only ANOVA analyses of model II (random components of uncertainty only) are considered.

Analysis of variance table referring to Chapter 5.2.2.2

LIN = linearity

N = number of standards

EVR = repeatability on standards

K = number of repetitions

Mean of the values measured on standard n	$y_{n\bullet} = \sum_k y_{nk}$	$\bar{y}_{n\bullet} = \frac{y_{nk}}{K}$
---	--------------------------------	---

	Sum of squares	Degrees of freedom	Mean square
LIN	$SS_{LIN} = \sum_n \sum_k (y_{nk} - \hat{y}_n)^2 - SS_{EVR}$	$f_{LIN} = N - 2$	$MS_{LIN} = \frac{SS_{LIN}}{f_{LIN}}$
EVR	$SS_{EVR} = \sum_n \sum_k (y_{nk} - \bar{y}_{n\bullet})^2$	$f_{EVR} = NK - N$	$MS_{EVR} = \frac{SS_{EVR}}{f_{EVR}}$

	Estimated variance	Estimated standard deviation	Test statistic F (F-Test)	Critical value F_0
LIN	$\hat{\sigma}^2_{LIN} = MS_{LIN}$	$\hat{\sigma}_{LIN} = \sqrt{\hat{\sigma}^2_{LIN}}$	$\frac{MS_{LIN}}{MS_{EVR}}$	$F(1 - \alpha, f_{LIN}, f_{EVR})$
EVR	$\hat{\sigma}^2_{EVR} = MS_{EVR}$	$\hat{\sigma}_{EVR} = \sqrt{\hat{\sigma}^2_{EVR}}$		

Analysis of variance tables referring to Chapter 5.3.1

AV = operator's reproducibility

N_A = number of operators

PV = reproducibility part to part

N_P = number of parts

IA = interaction operator - part

N_R = number of repetitions

EVO = repeatability on parts

Case 1: Uncertainty components from repeatability

Mean of the values measured on part p	$y_{p\bullet} = \sum_r y_{pr}$	$\bar{y}_{p\bullet} = \frac{y_{p\bullet}}{N_R}$
Overall mean	$y_{\bullet\bullet} = \sum_p \sum_r y_{pr}$	$\bar{y}_{\bullet\bullet} = \frac{y_{\bullet\bullet}}{N_R N_P}$

	Sum of squares	Degrees of freedom	Mean square
PV	$SS_{PV} = N_R \sum_p (\bar{y}_{p\bullet} - \bar{y}_{\bullet\bullet})^2$	$f_{PV} = N_P - 1$	$MS_{PV} = \frac{SS_{PV}}{f_{PV}}$
EVO	$SS_{EVO} = \sum_p \sum_r (\bar{y}_{pr} - \bar{y}_{p\bullet})^2$	$f_{EVO} = N_P (N_R - 1)$	$MS_{EVO} = \frac{SS_{EVO}}{f_{EVO}}$

	Estimated variance	Estimated standard deviation	Test statistic F (F-Test)	Critical value F_0
PV	$\hat{\sigma}^2_{PV} = \frac{MS_{PV} - MS_{EVO}}{N_R}$	/	$\frac{MS_{PV}}{MS_{EVO}}$	$F(1 - \alpha, f_{PV}, f_{EVO})$
EVO	$\hat{\sigma}^2_{EVO} = MS_{EVO}$		$\hat{\sigma}_{EVO} = \sqrt{\hat{\sigma}^2_{EVO}}$	/

Case 2: Uncertainty components from operator, repeatability and interactions between operator and part

Mean of the values measured on part p by operator a	$y_{ap\bullet} = \sum_r y_{apr}$	$\bar{y}_{ap\bullet} = \frac{y_{ap\bullet}}{N_R}$
Mean of the values measured by operator a	$y_{a\bullet\bullet} = \sum_r \sum_p y_{apr}$	$\bar{y}_{a\bullet\bullet} = \frac{y_{a\bullet\bullet}}{N_R N_P}$
Mean of the values measured on part p	$y_{\bullet p\bullet} = \sum_a \sum_r y_{apr}$	$\bar{y}_{\bullet p\bullet} = \frac{y_{\bullet p\bullet}}{N_R N_A}$
Overall mean	$y_{\bullet\bullet\bullet} = \sum_a \sum_p \sum_r y_{apr}$	$\bar{y}_{\bullet\bullet\bullet} = \frac{y_{\bullet\bullet\bullet}}{N_R N_A N_P}$

	Sum of squares	Degrees of freedom	Mean square
AV	$SS_{AV} = N_R N_P \sum_a (\bar{y}_{a\bullet\bullet} - \bar{y}_{\bullet\bullet\bullet})^2$	$f_{AV} = N_A - 1$	$MS_{AV} = \frac{SS_{AV}}{f_{AV}}$
PV	$SS_{PV} = N_R N_A \sum_a (\bar{y}_{\bullet p\bullet} - \bar{y}_{\bullet\bullet\bullet})^2$	$f_{PV} = N_P - 1$	$MS_{PV} = \frac{SS_{PV}}{f_{PV}}$
IA	$SS_{IA} = N_R \sum_a \sum_p (\bar{y}_{ap\bullet} - \bar{y}_{a\bullet\bullet} - \bar{y}_{\bullet p\bullet} + \bar{y}_{\bullet\bullet\bullet})^2$	$f_{IA} = (N_A - 1)(N_P - 1)$	$MS_{IA} = \frac{SS_{IA}}{f_{IA}}$
EVO	$SS_{EVO} = \sum_a \sum_p \sum_r (\bar{y}_{apr} - \bar{y}_{ap\bullet})^2$	$f_{EVO} = N_A N_P (N_R - 1)$	$MS_{EVO} = \frac{SS_{EVO}}{f_{EVO}}$

	Estimated variance	Estimated standard deviation	Test statistic F (F-Test)	Critical value F_0
AV	$\hat{\sigma}_{AV}^2 = \frac{MS_{AV} - MS_{IA}}{N_P N_R}$	$\hat{\sigma}_{AV} = \sqrt{\hat{\sigma}_{AV}^2}$	$\frac{MS_{AV}}{MS_{IA}}$	$F(1 - \alpha, f_{AV}, f_{IA})$
PV	$\hat{\sigma}_{PV}^2 = \frac{MS_{PV} - MS_{IA}}{N_A N_R}$	/	$\frac{MS_{PV}}{MS_{IA}}$	$F(1 - \alpha, f_{PV}, f_{IA})$
IA	$\hat{\sigma}_{IA}^2 = \frac{MS_{IA} - MS_{EVO}}{N_R}$		$\frac{MS_{IA}}{MS_{EVO}}$	$F(1 - \alpha, f_{IA}, f_{AVO})$
EVO	$\hat{\sigma}_{EVO}^2 = MS_{EVO}$	$\hat{\sigma}_{EVO} = \sqrt{\hat{\sigma}_{EVO}^2}$	/	/

If the interaction between the operator and the part is not significant, i.e. if $F < F_0$, repeatability and interaction should be combined to a single component (pooling).

Then:

- $SS_{Pool} = SS_{EVO} + SS_{IA}$ and $MS_{Pool} = \frac{SS_{Pool}}{f_{EVO} + f_{IA}}$
- MS_{Pool} replaces MS_{IA} in the *AV* and *PV* line of the variance table.
- The estimated standard deviation from repeatability is
 $\hat{\sigma}_{EVO} = \sqrt{MS_{Pool}}$

Case 3: Uncertainty components from measuring system, repeatability and interaction between measuring system and part

Similar to case 2, but replacing the operator by the measuring system.

Annex B Estimation of Standard Uncertainties from Temperature

Since most materials change as the temperature varies, the standard uncertainty from temperature u_T must be determined in all measurements (Figure 24).

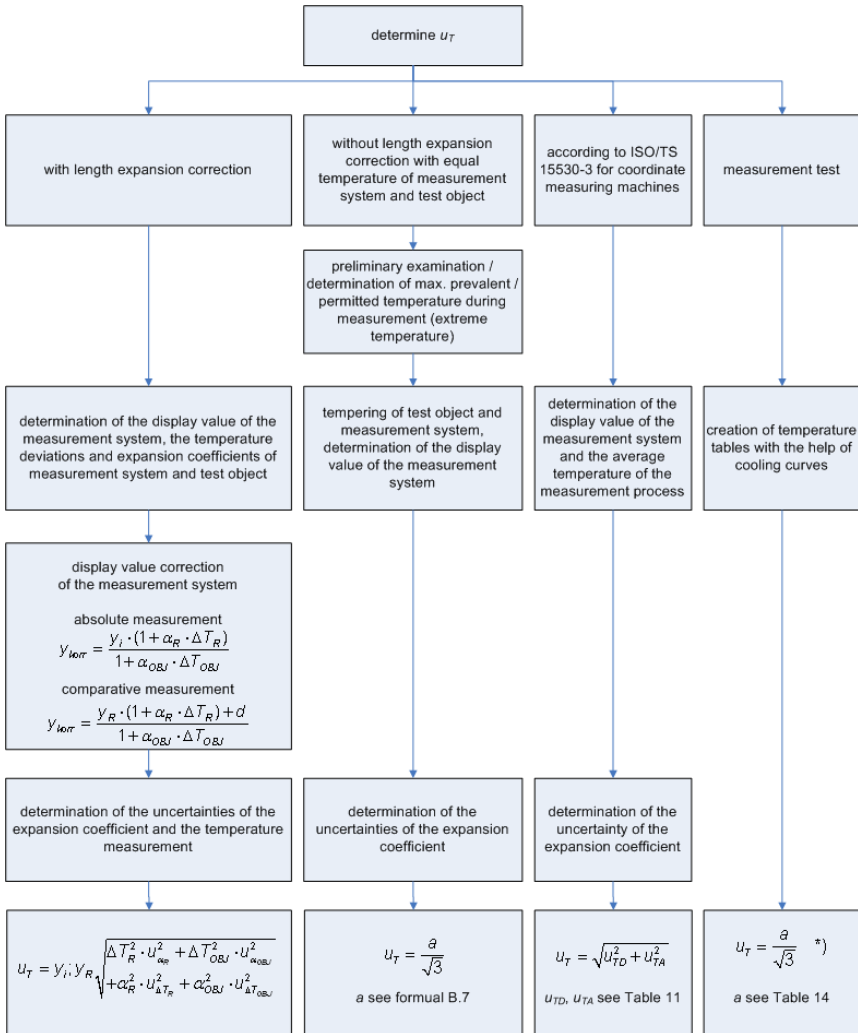

*) It must be taken into account that other uncertainty components may be included as well (i.e. u_{EVR}) in u_T and must not be considered twice.

Figure 24: Determining the standard uncertainty from temperature u_T

In comparing a test part (work part) to a reference standard or a scale, temperature variations do not affect the measurement result if the test part and the reference standard or scale are made of the same material and have the same temperature. If this is not the case, the measurement result is subject to an uncertainty caused by different expansion coefficients. Since these temperature variations can be quite high, the results should generally be corrected for these variations mathematically (compensation for temperature difference).

Annex B.1 Uncertainty with Correction of Different Linear Expansions

The calculation of corrected measured quantity value y_{corr} depends on the type of measurement:

Absolute measurement

$$y_{corr} = \frac{y_i \cdot (1 + \alpha_R \cdot \Delta T_R)}{1 + \alpha_{OBJ} \cdot \Delta T_{OBJ}} \quad \text{B.1}$$

- where
- y_i = value displayed by the measuring instrument
 - ΔT_{OBJ} = test part's deviation of temperature from 20° C
 - ΔT_R = reference standard's deviation of temperature from 20° C
 - α_{OBJ} = thermal expansion coefficient of test part
 - α_R = thermal expansion coefficient of reference standard (e.g. glass scale of a height gauge)

If a good approximation is available, the following formula applies:

$$y_{corr} \approx y_i \cdot [1 - (\alpha_{OBJ} \cdot \Delta T_{OBJ} - \alpha_R \cdot \Delta T_R)] \quad \text{B.2}$$

Comparison measurement

$$y_{corr} = \frac{y_R \cdot (1 + \alpha_R \cdot \Delta T_R) + d}{1 + \alpha_{OBJ} \cdot \Delta T_{OBJ}} \quad \text{B.3}$$

where :

- d = temperature difference (test part – reference standard)
- y_R = length of reference standard at reference temperature of 20° C
- ΔT_R = reference standard's deviation of temperature from 20° C
- α_R = thermal expansion coefficient of reference

If a good approximation is available, the following formula applies:

$$y_{corr} \approx y_R + d + y_R (\alpha_R \cdot \Delta T_R - \alpha_{OBJ} \cdot \Delta T_{OBJ}) \quad \text{B.4}$$

Since the (measured) temperatures and the thermal expansion coefficients used in the calculation also cause an uncertainty, an uncertainty from other influence components u_{REST} remains. Assuming that α_{OBJ} , α_R , ΔT_{OBJ} and ΔT_R are uncorrelated and that there are no changes in temperature during the measurement, the standard uncertainty from temperature is calculated by:

$$u_T = u_{REST} = y_i \cdot y_R \sqrt{\Delta T_R^2 u_{\alpha_R}^2 + \Delta T_{OBJ}^2 u_{\alpha_{OBJ}}^2 + \alpha_R^2 u_{\Delta T_R}^2 + \alpha_{OBJ}^2 u_{\Delta T_{OBJ}}^2} \quad \text{B.5}$$

In case no further data is available, the uncertainty from expansion coefficients is assumed to be 10 % of these coefficients and the uncertainty from temperature amounts to 1 Kelvin. If temperature variations (drifts) might occur during the measurement, these influences must possibly also be considered.

As an example, Table B.1 lists uncertainties from other influence components caused in measurements on test parts made of different materials and by using different scales or reference standards. All these examples are based on the assumption that the temperature of the test part and the measuring instrument is nearly the same (test part has been controlled) and that the temperature is constant during the measurement. It is also assumed that $u_{\alpha_{OBJ;R}} = 0,1 \cdot \alpha_{OBJ;R}$ and $u_{\Delta T_{OBJ;R}} = 1 \text{ Kelvin}$.

Gauge Standard	Material of the test part	Uncertainty from other influence components u_T in μm per 100 mm with a temperature deviation $\Delta T_{OBJ;R}$ from 20 °C						
		0 K	2,5 K	5 K	7,5 K	10 K	12,5 K	15 K
Steel	Aluminium $\alpha_{OBJ} = 24 \cdot 10^{-6} \text{ 1/K}$	2,7	2,7	3,0	3,3	3,8	4,3	4,8
	Brass $\alpha_{OBJ} = 18 \cdot 10^{-6} \text{ 1/K}$	2,1	2,2	2,4	2,7	3,0	3,4	3,9
	Steel $\alpha_{OBJ} = 11,5 \cdot 10^{-6} \text{ 1/K}$	1,6	1,7	1,8	2,0	2,3	2,6	2,9
	Cast iron $\alpha_{OBJ} = 10 \cdot 10^{-6} \text{ 1/K}$	1,5	1,6	1,7	1,9	2,2	2,4	2,7
Ceramic	Aluminium $\alpha_{OBJ} = 24 \cdot 10^{-6} \text{ 1/K}$	2,6	2,7	2,9	3,2	3,7	4,1	4,7
	Brass $\alpha_{OBJ} = 18 \cdot 10^{-6} \text{ 1/K}$	2,0	2,1	2,3	2,5	2,9	3,3	3,7
	Steel $\alpha_{OBJ} = 11,5 \cdot 10^{-6} \text{ 1/K}$	1,5	1,5	1,7	1,9	2,1	2,4	2,7
	Cast iron $\alpha_{OBJ} = 10 \cdot 10^{-6} \text{ 1/K}$	1,4	1,4	1,5	1,7	2,0	2,2	2,5
Glass	Aluminium $\alpha_{OBJ} = 24 \cdot 10^{-6} \text{ 1/K}$	2,5	2,6	2,8	3,2	3,6	4,0	4,6
	Brass $\alpha_{OBJ} = 18 \cdot 10^{-6} \text{ 1/K}$	2,0	2,0	2,2	2,5	2,8	3,2	3,6
	Steel $\alpha_{OBJ} = 11,5 \cdot 10^{-6} \text{ 1/K}$	1,4	1,4	1,6	1,8	2,0	2,2	2,5
	Cast iron $\alpha_{OBJ} = 10 \cdot 10^{-6} \text{ 1/K}$	1,3	1,3	1,4	1,6	1,8	2,1	2,3
System without expansion $\alpha_R \approx 0 \text{ 1/K}$	Aluminium $\alpha_{OBJ} = 24 \cdot 10^{-6} \text{ 1/K}$	2,4	2,5	2,7	3,0	3,4	3,8	4,3
	Brass $\alpha_{OBJ} = 18 \cdot 10^{-6} \text{ 1/K}$	1,8	1,9	2,0	2,3	2,5	2,9	3,2
	Steel $\alpha_{OBJ} = 11,5 \cdot 10^{-6} \text{ 1/K}$	1,2	1,2	1,3	1,4	1,6	1,8	2,1
	Cast iron $\alpha_{OBJ} = 10 \cdot 10^{-6} \text{ 1/K}$	1,0	1,0	1,1	1,3	1,4	1,6	1,8

Table B.1: Standard uncertainty u_T from test parts made of different materials using different scales or reference standards in case a compensation for temperature difference is made (in this table K stands for Kelvin)

Annex B.2 Uncertainty without Correction of Different Linear Expansions

Since most cases occurring in practice do not allow for a correction by calculation, errors that are caused by different expansions at temperatures deviating from 20° C must also be considered.

The following procedure is based on the assumption that the temperature of the test part and the measuring instrument is nearly the same during the measurement (test part has been controlled) and that a specified maximum temperature deviating from 20° C is not exceeded. The greatest possible measurement error that can occur at a maximum temperature t_{max} is regarded as the error limit a caused by temperature influences.

Note 1: This approach particularly applies to temperature-controlled measuring laboratories where the actual temperature is stable between a reasonable maximum and a minimum temperature around the reference temperature of 20° C.

Note 2: If a high maximum temperature is permissible, its resulting uncertainty component frequently makes up a major part of the uncertainty budget and often causes an unsatisfactory expanded measurement uncertainty U_{MP} that is extremely high.

Due to different linear expansions at the maximum temperature t_{max} , the measurement error Δy_i , in case of a good approximation, is calculated by:

$$\Delta y \approx y_i; y_R \cdot (t_{max} - 20^\circ) \cdot (\alpha_{OBJ} - \alpha_R) \quad \text{B.6}$$

This measurement error is added to the uncertainty from different expansion coefficients α_R or α_{OBJ} (at t_{max}) and leads to the maximum permissible error a (worst case) caused by temperature variations.

$$a = |\Delta y_i| + 2u_{REST} \quad \text{where}$$

$$u_{REST} = y_i; y_R \cdot \sqrt{\Delta T_R^2 \cdot u_{\alpha_R}^2 + \Delta T_{OBJ}^2 \cdot u_{\alpha_{OBJ}}^2} \quad \text{B.7}$$

Thereby u_{REST} is calculated as described in formula B.5, but leaving out the uncertainty components of the temperature measurement that was not taken in this case ($\alpha_R^2 \cdot u_{\Delta T_R}^2 = 0$ and $\alpha_{OBJ}^2 \cdot u_{\Delta T_{OBJ}}^2 = 0$).

This leads to the standard uncertainty from temperature:

$$u_T = \frac{a}{\sqrt{3}} \tag{B.8}$$

As an example, Table B.2 lists uncertainties from other influence components caused in measurements on test parts made of different materials using different scales or reference standards when the different linear expansions where not corrected by calculation. It is assumed that

$$u_{\alpha_{OBJ;R}} = 0,1 \cdot \alpha_{OBJ;R}.$$

Note 1: Strictly speaking, the uncertainty calculated by the methods described above only applies to rod-shaped test parts with a homogeneous temperature. By contrast, it is difficult to estimate the thermal expansion and thus the uncertainty from expansion coefficients for any other, particularly asymmetric test parts. However, the uncertainty generally only becomes smaller compared to the rod-shaped test part so that one is always “on the safe side”.

Note 2: The tables show that a different thermal expansion coefficient of the test part and the reference standard result in high uncertainties. This leads to the conclusion that measuring instruments including scales with very small thermal expansion coefficients cause a high measurement uncertainty if a compensation for temperature difference is not made. In general, these measuring instruments require a correction of temperature influences by calculation.

Gauge Standard	Material of the test part	Uncertainty from other influence components u_T in μm per 100 mm with a temperature deviation $\Delta T_{OBJ,R}$ from 20° C						
		0,5 K	1 K	2,5 K	5 K	7,5 K	10 K	15 K
Steel	Aluminium $\alpha_{OBJ} = 24 \cdot 10^{-6} \text{ 1/K}$	0,5	1,0	2,6	5,1	7,7	10,3	15,4
	Brass $\alpha_{OBJ} = 18 \cdot 10^{-6} \text{ 1/K}$	0,3	0,6	1,6	3,1	4,7	6,2	9,3
	Steel $\alpha_{OBJ} = 11,5 \cdot 10^{-6} \text{ 1/K}$	0,1	0,2	0,5	0,9	1,4	1,9	2,8
	Cast iron $\alpha_{OBJ} = 10 \cdot 10^{-6} \text{ 1/K}$	0,1	0,3	0,7	1,3	2,0	2,6	3,9
Ceramic	Aluminium $\alpha_{OBJ} = 24 \cdot 10^{-6} \text{ 1/K}$	0,6	1,1	2,8	5,7	8,5	11,4	17,0
	Brass $\alpha_{OBJ} = 18 \cdot 10^{-6} \text{ 1/K}$	0,4	0,7	1,8	3,6	5,4	7,3	10,9
	Steel $\alpha_{OBJ} = 11,5 \cdot 10^{-6} \text{ 1/K}$	0,1	0,3	0,7	1,4	2,2	2,9	4,3
	Cast iron $\alpha_{OBJ} = 10 \cdot 10^{-6} \text{ 1/K}$	0,1	0,2	0,5	0,9	1,4	1,9	2,8
Glass	Aluminium $\alpha_{OBJ} = 24 \cdot 10^{-6} \text{ 1/K}$	0,6	1,2	3,0	6,1	9,1	12,2	18,2
	Brass $\alpha_{OBJ} = 18 \cdot 10^{-6} \text{ 1/K}$	0,4	0,8	2,0	4,0	6,0	8,0	12,1
	Steel $\alpha_{OBJ} = 11,5 \cdot 10^{-6} \text{ 1/K}$	0,2	0,4	0,9	1,8	2,7	3,6	5,5
	Cast iron $\alpha_{OBJ} = 10 \cdot 10^{-6} \text{ 1/K}$	0,1	0,3	0,7	1,3	2,0	2,6	4,0
System without expansion	Aluminium $\alpha_{OBJ} = 24 \cdot 10^{-6} \text{ 1/K}$	0,8	1,7	4,2	8,3	12,5	16,6	24,9
	Brass $\alpha_{OBJ} = 18 \cdot 10^{-6} \text{ 1/K}$	0,6	1,2	3,1	6,2	9,4	12,5	18,7
	Steel $\alpha_{OBJ} = 11,5 \cdot 10^{-6} \text{ 1/K}$	0,4	0,8	2,0	4,0	6,0	8,0	12,0
	Cast iron $\alpha_{OBJ} = 10 \cdot 10^{-6} \text{ 1/K}$	0,3	0,7	1,7	3,5	5,2	6,9	10,4

Table B.2: Standard uncertainty u_T from test parts made of different materials using different scales or reference standards in case a compensation for temperature difference is not made (in this table K stands for Kelvin)

Annex C Reducing the Measurement Uncertainty by Repeating and Averaging Measurements

The measurement uncertainty can be reduced by repeating and averaging measurements. By taking repeated measurements instead of an individual measurement, the random measurement uncertainty components can be reduced by a factor of $\sqrt{n^*}$. Prior to that, the standard uncertainty must be determined based on 25 repeated measurements under equal conditions of measurement, i.e. the standard deviation of a previous series of measurements is used in order to express the measurement uncertainty (cf. Chapter 5).

The figure below shows how raising the number of measured quantity values n^* reduces the standard uncertainty.

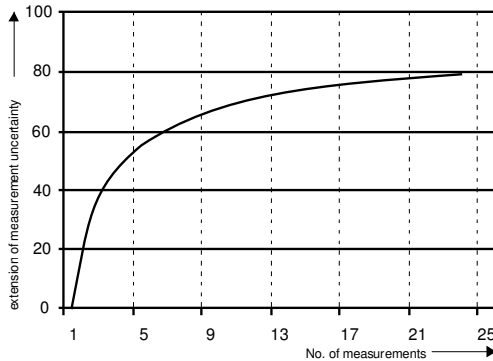

Figure A.D.1: Reducing the measurement uncertainty by raising the number of repeated measurements n^*

In case of an individual measurement of a characteristic, the experimentally determined repeatability of the measuring instrument is included in the uncertainty budget in the form of u_{EVR} or u_{EVO} (cf. Chapter 5.2 and 5.3). If a measurement result is obtained by repeating and averaging the measurement of one characteristic, the influence of the variation is reduced. The uncertainty component from repeatability on test parts is not calculated from the variation of individual measured quantity values but from the smaller random variation of the means of these measured values.

$$u_{EVO^*} = \frac{u_{EVO}}{\sqrt{n^*}}$$

where n^* is the number of measurements required for averaging the measurement. In the uncertainty budget, the uncertainty u_{EVO^*} replaces the uncertainty u_{EVO} that was determined experimentally during the capability analysis. It is important to consider that only the greatest value of u_{EVR} , u_{EVO} or u_{RE} is considered in the uncertainty budget. For this reason, the standard uncertainty from repeatability on standards u_{EVR} must always be replaced by u_{EVR^*} which is reduced by a factor of $\sqrt{n^*}$. It must also be compared to the uncertainty from resolution of the measuring system u_{RE} .

Example: An experiment led to the following uncertainty budget:

$$u_{CAL} = 0,8 \mu\text{m}, u_{EVR} = 0,9 \mu\text{m}, u_{EVO} = 1,1 \mu\text{m}, u_{RE} = 0,6 \mu\text{m}, u_{AV} = 1,3 \mu\text{m}$$

measured quantity value of **individual measurement**: $\varnothing 20,354 \text{ mm}$

The combined standard uncertainty

$$u_{MP} = \sqrt{u_{CAL}^2 + \max\{u_{EVR}^2; u_{EVO}^2; u_{RE}^2\} + u_{AV}^2}$$

is calculated using the uncertainty components listed above:

$$u_{MP} = \sqrt{u_{CAL}^2 + u_{EVO}^2 + u_{AV}^2} = \sqrt{0,8^2 + 1,1^2 + 1,3^2} = \underline{1,88 \mu\text{m}}$$

measurement result: $\varnothing 20,354 \text{ mm} \pm 3,76 \mu\text{m} (k=2)$.

measured quantity values of repeated measurement: $\varnothing 20,354 \text{ mm}; \varnothing 20,348 \text{ mm}; \varnothing 20,352 \text{ mm}$

Based on $n^* = 3$ repeated measurements, the uncertainty amounts to $u_{EVO^*} = 1,1/\sqrt{3} = 0,64 \mu\text{m}$ or $u_{EVR^*} = 0,9/\sqrt{3} = 0,52 \mu\text{m}$, whereby u_{MP} is reduced

$$u_{MP} = \sqrt{u_{CAL}^2 + u_{EVO^*}^2 + u_{AV}^2} = \sqrt{0,8^2 + 0,64^2 + 1,3^2} = \underline{1,66 \mu\text{m}}$$

measurement result: $\varnothing 20,3513 \text{ mm} \pm 3,32 \mu\text{m} (k=2)$.

If the number of repeated measurements is raised once again, e.g. to $n^* = 5$, the uncertainty is even more reduced $u_{EVO^*} = 1,1/\sqrt{5} = 0,49 \mu\text{m}$ or $u_{EVR^*} = 0,9/\sqrt{5} = 0,40 \mu\text{m}$. However, this does not lead to a considerable improvement of the measurement result because the uncertainty from resolution $u_{RE} = 0,6$ is the greatest uncertainty component. Thus, it is the only component of the measuring instrument to be considered in the result.

$$u_{MP} = \sqrt{u_{CAL}^2 + u_{RE}^2 + u_{AV}^2} = \sqrt{0,8^2 + 0,6^2 + 1,3^2} = \underline{\underline{1,64 \mu\text{m}}}$$

Annex D **k** Factors

If the specified design of experiments cannot be realized in terms of the demanded sample size, it is necessary to take a Student t-distribution instead of the standard normal distribution to estimate the uncertainty components. This will then result in the expanded measurement uncertainty:

$$U_{MP} = t_{f,1-\alpha/2} \cdot u_{MP}$$

The number of degrees of freedom f is obtained from the product of the number of test parts, the number of operators, the number of measuring systems and the number of repeatability measurements reduced by one.

For $f = 3 \cdot 2 \cdot 2 \cdot (3 - 1) = 24$ one will find $t_{24,1-\alpha/2} = 2,11,$

For $f = 3 \cdot 2 \cdot 2 \cdot (2 - 1) = 12$ one will find $t_{12,1-\alpha/2} = 2,23 .$

degree of freedom f	1	2	3	4	5	6	7	8	9	10	11	12	13	14	$\rightarrow \infty$
k values (p=95,45%)	13,97	4,53	3,31	2,87	2,65	2,52	2,43	2,37	2,32	2,28	2,25	2,23	2,21	2,20	2,0

Table 15: k values for a 95,45% level of confidence according to the respective degree of freedom

Annex E Setting Working Point(s)

Before a measuring system can be applied for measurements, it must normally be set using one or two reference standard(s). The measuring system is set according to the calibrated actual value of the standard (working standard) which makes the system ready for use.

Depending on the measurement procedure or measuring system, there are different methods available in order to set the system.

Setting a working point using a calibrated reference standard

Determination of the systematic measurement error and the repeatability (Type 1 study):

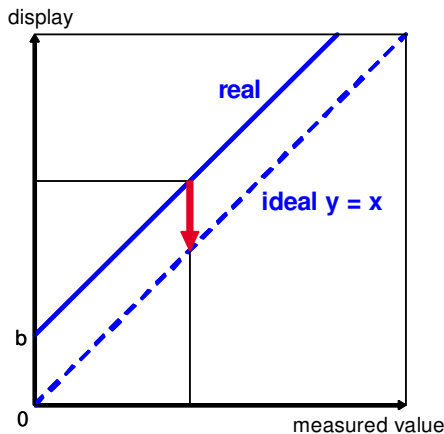

This method is applied to linear measuring systems for setting the working point. The value of the reference standard shall lie within an area of +/-10 % around the working point.

Setting working points using two calibrated reference standards

Determination of the systematic measurement error and the repeatability (Type 1 study):

Case 1

This method is applied to linear measuring systems for setting zero on the system or for boosting. The values of the reference standard shall lie within an area of +/-10% around the zero point and the upper working point. The uncertainty components are determined from the repeatability variation on the reference standards and from the deviations of the calculated means from the calibrated actual values of the reference standards (using the greatest value in each case).

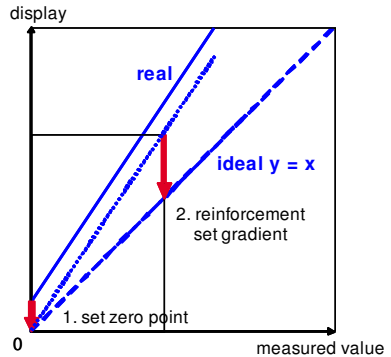

Case 2

This method is used in order to set the upper and lower specification limit on the measuring system. The values of the reference standard shall lie within an area of +/-10% around the limits. The uncertainty components are determined from the repeatability variation on the reference standards and from the deviations of the calculated means from the calibrated actual values of the reference standards (using the greatest value in each case).

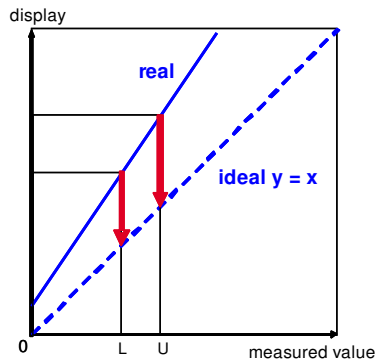

Annex F Calculation Examples

Annex F.1 Measurement Process Capability Using 3 Standards

An instrument measuring boltholes requires that the capability of the measurement process for inside diameters should be established and documented. Uncertainties from test part or the temperature are regarded as negligible and are not considered in the evaluation.

Information about measuring system and measurement process	
Nominal dimension	30,000 mm
Upper specification limit U	30,008 mm
Lower specification limit L	30,003 mm
Resolution of the measuring system RE (1 digit = 0,0001mm)	0,1 μm
Calibration uncertainty U_{CAL}	0,026 μm
Coverage factor k_{CAL}	2
Linearity	0
Reference quantity value of the standard at the upper specification limit x_{mu}	30,0076 mm
Reference quantity value of the standard in the centre of the specification x_{mm}	30,0050 mm
Reference quantity value of the standard at the lower specification limit x_{ml}	30,0025 mm
Capability ratio limit measuring system Q_{MS_max}	15%
Capability ratio limit measurement process Q_{MP_max}	30%

In order to determine the standard uncertainties from repeatability on standards and from measurement bias, an experiment was conducted performing 10 repeated measurements on each of 3 reference standards.

	Standard 1	Standard 2	Standard 3
Reference value	30,0076	30,0050	30,0025
Trial 1	30,0075	30,0050	30,0025
Trial 2	30,0075	30,0051	30,0024
Trial 3	30,0077	30,0051	30,0024
Trial 4	30,0075	30,0050	30,0023
Trial 5	30,0076	30,0052	30,0025
Trial 6	30,0076	30,0051	30,0024
Trial 7	30,0076	30,0050	30,0023
Trial 8	30,0075	30,0051	30,0023
Trial 9	30,0076	30,0051	30,0024
Trial 10	30,0076	30,0052	30,0024

The information about the measuring system and the measured quantity values gained in the experiment leads to the following uncertainty budget and overview of results.

Uncertainty components	Symbol	Type	u	Rank
Resolution of the measuring system	u_{RE}	B	0.0000289	3*
Calibration uncertainty	u_{CAL}	B	0.0000130	4
Repeatability on reference standard	u_{EVR}	A	0.0000738	1
Uncertainty from linearity	u_{LIN}	B		
Uncertainty from Bias	u_{BI}	A	0.0000635	2
Measurement system	u_{MS}		0.0000982	

Tolerance	TOL	=	0.0050	
Resolution	%RE	=	2.00%	
Combined standard uncertainty	u_{MS}	=	0.0000982	
Expanded measurement uncertainty	U_{MS}	=	0.000196	
Capability ratio limit	Q_{MS_max}	=	15.00%	
Capability ratio	Q_{MS}	=	7.86%	
Minimum tolerance	$TOL_{MIN-U_{MS}}$	=	0.00262	

Due to a percentage resolution %RE of 2,00% and a capability ratio Q_{MS} of 7,86%, the capability of the measuring system of the instrument measuring boltholes is established.

After the capability of the measuring system is established, the measurement process is analyzed. The operator influence, the repeatability on test parts and their interactions are determined experimentally under operational conditions. In this experiment, 2 repeated measurements are performed on each of 10 test parts by 3 operators.

	Operator A		Operator B		Operator C	
	Trial 1	Trial 2	Trial 1	Trial 2	Trial 1	Trial 2
1	30,0054	30,0055	30,0057	30,0058	30,0058	30,0057
2	30,0056	30,0058	30,0059	30,0054	30,0057	30,0058
3	30,0053	30,0054	30,0055	30,0055	30,0056	30,0059
4	30,0041	30,0042	30,0043	30,0044	30,0045	30,0042
5	30,0051	30,0053	30,0055	30,0049	30,0052	30,0049
6	30,0050	30,0052	30,0054	30,0055	30,0055	30,0053
7	30,0049	30,0050	30,0049	30,0052	30,0051	30,0051
8	30,0056	30,0056	30,0057	30,0059	30,0058	30,0057
9	30,0054	30,0055	30,0056	30,0057	30,0054	30,0056
10	30,0057	30,0058	30,0059	30,0061	30,0057	30,0061

Based on the recorded measured quantity values, the individual standard uncertainties can be determined and allocated by using the method of ANOVA. This leads to the following uncertainty budget and overview of results for the measurement process.

Uncertainty components	Symbol	Type	u	Rank
Resolution of the measuring system	u_{RE}	B	0.0000289	5*
Calibration uncertainty	u_{CAL}	B	0.0000130	6
Repeatability on reference standard	u_{EVR}	A	0.0000738	3*
Uncertainty from linearity	u_{LIN}	B		
Uncertainty from Bias	u_{BI}	A	0.0000635	4
Measurement system	u_{MS}		0.0000982	
Reproducibility of operators	u_{AV}	A	0.0000892	2
Repeatability on test parts	u_{EVO}	A	0.000151	1
Uncertainty from interactions	u_{IAI}	A	[pooling]	
Measurement process	u_{MP}		0.000187	

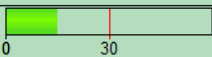
Combined standard uncertainty	u_{MP}	=	0.000187	
Expanded measurement uncertainty	U_{MP}	=	0.000374	
Capability ratio limit	Q_{MP_max}	=	30.00%	
Capability ratio	Q_{MP}	=	14.98%	
Minimum tolerance	$TOL_{MIN-UMP}$	=	0.00250	

Due to a capability ratio Q_{MP} of 14,98% in case of a process capability ratio limit Q_{MP_max} of 30%, the capability of the measurement process of the instrument measuring boltholes is established.

Annex F.2 Process Capability Using a D-optimum Design

Analogous to the example in Annex F.1, a new measurement process capability analysis should be made for the instrument measuring boltholes. However, in this case, the additional uncertainty component caused by the test part influence shall be considered. It is determined by taking further measurements at 4 different measuring points of the inside diameter. In order to minimize the effort for this experiment, the experiment is reduced to a minimum of measurements with the help of a D-optimum experimental design.

The specifications, measured quantity values and results of the measuring system are the same as in the example of Annex F.1 and can be transferred to this example.

For the measurement process, a D-optimum experimental design is created including 2 repeated measurements at each of 4 measuring points of 10 test parts by 3 operators. The D-optimum experimental design reduces the effort involved from 240 to 128 individual measurements. These are taken in random combinations of operator/test part/measuring point and evaluated by using the method of ANOVA.

The information about the measuring system (see Annex F.1) and the measured quantity values of the D-optimum experimental design lead to the following uncertainty budget and overview of results.

	Part	Operator	Test point	Value		Part	Operator	Test point	Value		Part	Operator	Test point	Value
1	1	2	3	30,0059	45	9	2	4	30,0059	89	10	2	3	30,0062
2	2	3	1	30,0057	46	7	1	4	30,0054	90	1	3	3	30,0060
3	1	3	1	30,0054	47	7	3	3	30,0055	91	4	2	3	30,0046
4	6	1	1	30,0050	48	4	1	1	30,0041	92	1	1	2	30,0055
5	2	1	4	30,0060	49	5	3	4	30,0053	93	4	1	4	30,0045
6	4	1	2	30,0042	50	4	2	1	30,0043	94	1	2	4	30,0060
7	7	3	4	30,0054	51	8	1	4	30,0057	95	7	2	3	30,0052
8	5	2	3	30,0058	52	2	3	4	30,0060	96	2	2	1	30,0059
9	4	3	1	30,0045	53	6	3	3	30,0059	97	7	3	1	30,0051
10	3	2	1	30,0055	54	7	2	4	30,0052	98	3	2	2	30,0056
11	6	1	4	30,0054	55	8	1	2	30,0055	99	3	3	4	30,0060
12	8	3	2	30,0058	56	8	2	4	30,0062	100	1	3	2	30,0058
13	10	3	4	30,0061	57	4	3	4	30,0049	101	9	3	3	30,0057
14	6	1	3	30,0053	58	10	1	2	30,0058	102	9	3	2	30,0055
15	10	1	4	30,0061	59	4	3	3	30,0050	103	2	1	1	30,0058
16	3	2	4	30,0058	60	10	3	2	30,0059	104	10	1	3	30,0060
17	5	3	1	30,0056	61	1	1	3	30,0057	105	3	1	4	30,0057
18	10	2	2	30,0060	62	6	2	4	30,0058	106	8	2	3	30,0060
19	8	3	1	30,0058	63	5	3	3	30,0056	107	8	1	3	30,0059
20	2	3	3	30,0059	64	2	2	4	30,0063	108	6	3	4	30,0058
21	9	1	3	30,0056	65	2	2	3	30,0062	109	10	3	1	30,0057
22	6	3	2	30,0056	66	3	1	1	30,0053	110	6	1	2	30,0052
23	3	1	3	30,0055	67	10	2	4	30,0062	111	1	1	4	30,0058
24	1	1	1	30,0055	68	3	2	3	30,0058	112	6	2	1	30,0054
25	9	1	1	30,0054	69	4	1	3	30,0045	113	9	2	2	30,0057
26	5	3	4	30,0055	70	10	2	1	30,0061	114	5	1	4	30,0055
27	10	1	1	30,0057	71	8	1	1	30,0053	115	9	1	4	30,0058
28	6	2	2	30,0055	72	7	1	1	30,0050	116	3	3	2	30,0059
29	3	3	3	30,0059	73	5	1	3	30,0055	117	7	2	1	30,0049
30	6	3	1	30,0055	74	5	1	1	30,0051	118	9	1	2	30,0055
31	9	3	4	30,0058	75	3	3	2	30,0060	119	8	2	1	30,0057
32	1	2	2	30,0058	76	2	2	2	30,0060	120	7	1	3	30,0053
33	3	1	2	30,0054	77	6	2	3	30,0057	121	9	1	3	30,0058
34	10	2	1	30,0059	78	8	2	2	30,0059	122	7	2	2	30,0050
35	3	3	1	30,0059	79	1	2	2	30,0058	123	1	3	4	30,0061
36	2	3	2	30,0059	80	8	3	3	30,0061	124	5	2	1	30,0055
37	4	2	4	30,0048	81	7	1	2	30,0050	125	2	2	3	30,0058
38	5	3	2	30,0054	82	2	1	2	30,0058	126	4	3	2	30,0045
39	7	3	2	30,0052	83	2	1	3	30,0060	127	5	2	4	30,0058
40	9	3	1	30,0054	84	1	2	1	30,0057	128	10	3	3	30,0061
41	6	1	4	30,0055	85	9	2	1	30,0056	129				
42	7	1	1	30,0049	86	9	2	3	30,0059	130				
43	5	1	2	30,0053	87	5	2	2	30,0055	131				
44	4	2	2	30,0044	88	8	3	4	30,0062	132				

Table 16: Measured quantity values of the D-optimum experimental design

Uncertainty components	Symbol	Type	u	Rank
Resolution of the measuring system	u_{RE}	B	0.0000289	7*
Calibration uncertainty	u_{CAL}	B	0.0000130	8
Repeatability on reference standard	u_{EVR}	A	0.0000738	5*
Uncertainty from linearity	u_{LIN}	B		
Uncertainty from Bias	u_{BI}	A	0.0000635	6
Measurement system	u_{MS}		0.0000982	
Reproducibility of operators	u_{AV}	A	0.000117	2
Repeatability on test parts	u_{EVO}	A	0.0000962	4
Test part inhomogeneity	u_{OBJ}	A	0.000159	1
Uncertainty from interactions	u_{IAI}	A	0.000111	3
Measurement process	u_{MP}		0.000255	

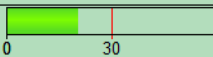
Combined standard uncertainty	u_{MP}	=	0.000255	
Expanded measurement uncertainty	U_{MP}	=	0.000510	
Capability ratio limit	Q_{MP_max}	=	30.00%	
Capability ratio	Q_{MP}	=	20.38%	
Minimum tolerance	$TOL_{MIN-UMP}$	=	0.00340	

Due to a capability ratio Q_{MP} of 20,38% in case of a process capability ratio limit Q_{MP_max} of 30%, the capability of the measurement process of the instrument measuring boltholes is established.

Annex F.3 Measurement Process Capability of a CMM

Measuring the inside diameter of a pump housing on a reference standard by using a coordinate measuring machine requires that the capability of the measurement process is established and documented.

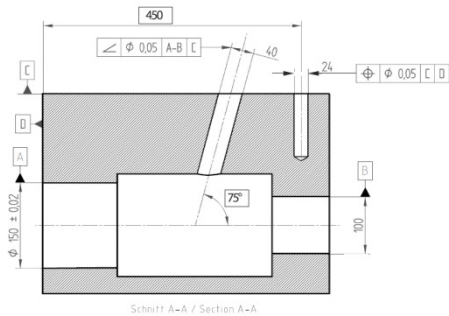

Information about measuring system and measurement process	
Nominal dimension	150,00 mm
Upper specification limit U	150,02 mm
Lower specification limit L	149,98 mm
Resolution of the measuring system RE (1 digit = 0,0001mm)	0,1 μ m
Reference quantity value of the standard	150,0015 mm
Calibration uncertainty U_{CAL}	2 μ m
Coverage factor k_{CAL}	2
Linearity	0
Capability ratio limit measuring system Q_{MS_max}	15%
Standard uncertainty from expansion coefficients of the test part $u_{\alpha OBI}$	$1 \cdot 10^{-6}/K$
Mean temperature of the measurement process	22 °C
Value displayed by measuring system	150,00 mm
Capability ratio limit measurement process Q_{MP_max}	30%

In order to determine the standard uncertainties from repeatability on standards and from measurement bias, 20 repeated measurements were performed on a reference standard. Since the linearity deviation is zero, the linearity can be neglected.

	Standard 1		Standard 1
Trial 1	150,0037	Trial 11	150,0021
Trial 2	150,0043	Trial 12	150,0024
Trial 3	150,0030	Trial 13	150,0024
Trial 4	150,0021	Trial 14	150,0030
Trial 5	150,0033	Trial 15	150,0031
Trial 6	150,0039	Trial 16	150,0034
Trial 7	150,0032	Trial 17	150,0022
Trial 8	150,0027	Trial 18	150,0020
Trial 9	150,0025	Trial 19	150,0018
Trial 10	150,0032	Trial 20	150,0030

The information about the measuring system and the measured quantity values gained in the experiment lead to the following uncertainty budget and overview of results.

Uncertainty components	Symbol	Type	u	Rank
Resolution of the measuring system	u_{RE}	B	0.0000289	4*
Calibration uncertainty	u_{CAL}	B	0.00100	1
Repeatability on reference standard	$u_{EV/R}$	A	0.000678	3
Uncertainty from linearity	u_{LIN}	B		
Uncertainty from Bias	u_{BI}	A	0.000788	2
Measurement system	u_{MS}		0.00144	

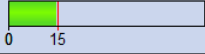
Tolerance	TOL	=	0.0400	
Resolution	%RE	=	0.25%	
Combined standard uncertainty	u_{MS}	=	0.00144	
Expanded measurement uncertainty	U_{MS}	=	0.00288	
Capability ratio limit	Q_{MS_max}	=	15.00%	
Capability ratio	Q_{MS}	=	14.42%	
Minimum tolerance	TOL _{MIN-UMS}	=	0.0385	

Due to a percentage resolution %RE of 0,25% and a capability ratio Q_{MS} of 14,42%, the capability of the measuring system of the CMM is established.

Since the measurement process capability only refers to one reference standard and a CMM does not involve a classical operator influence, the uncertainty from temperature is considered for this measurement process as described in ISO/TS 15530-3 [16].

This leads to the following uncertainty budget and overview of results for the measurement process.

Uncertainty components	Symbol	Type	u	Rank
Resolution of the measuring system	u_{RE}	B	0.0000289	5*
Calibration uncertainty	u_{CAL}	B	0.00100	1
Repeatability on reference standard	u_{EVR}	A	0.000678	3
Uncertainty from linearity	u_{LIN}	B		
Uncertainty from Bias	u_{BI}	A	0.000788	2
Measurement system	u_{MS}		0.00144	
Uncertainty from temperature	u_T	B	0.000300	4
Measurement process	u_{MP}		0.00147	

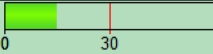
Combined standard uncertainty	u_{MP}	=	0.00147	
Expanded measurement uncertainty	U_{MP}	=	0.00295	
Capability ratio limit	Q_{MP_max}	=	30.00%	
Capability ratio	Q_{MP}	=	14.73%	
Minimum tolerance	$TOL_{MIN-UMP}$	=	0.0196	

Due to a capability ratio Q_{MP} of 14,73% in case of a process capability ratio limit Q_{MP_max} of 30%, the measurement process capability of the CMM for measuring the inside diameter on a reference standard is established.

Annex F.4 Measurement Process Capability of Automated Test Device

The measurement process capability of automated test device must be established and documented.

Information about measuring system and measurement process	
Nominal dimension	53,01 mm
Upper specification limit U	53,03 mm
Lower specification limit L	52,99 mm
Resolution of the measuring system RE (1 digit = 0,0001mm)	0,5 μm
Calibration uncertainty U_{CAL}	1,6 μm
Coverage factor k_{CAL}	2
Linearity u_{LIN} (from preliminary investigation)	0
f_{max} of dial gauge (MPE)	1,2 μm
Reference quantity value of standard	53,0105 mm
Capability ratio limit of measuring system Q_{MS_max}	15%
Expansion coefficient α of test part for steel	11,5 1/K · 10 ⁻⁶ /K
Expansion coefficient α of measuring system for steel	11,5 1/K · 10 ⁻⁶ /K
Standard uncertainty from expansion coefficients of test part $u_{\alpha OBI}$ for steel	1,2 1/K · 10 ⁻⁶ /K
Standard uncertainty from expansion coefficients of measuring system $u_{\alpha R}$ for steel	1,2 1/K · 10 ⁻⁶ /K
Maximum temperature (environment)	25 °C
Delta temperature of working standard at 20 °C	5 °C
Delta temperature of working standard at 20 °C	10 °C
Value displayed by measuring system	53 mm
Capability ratio limit measurement process Q_{MP_max}	30%

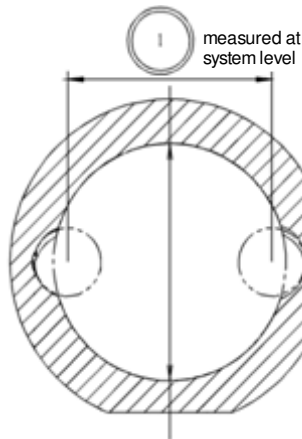

In order to determine the standard uncertainties from repeatability on standards and from measurement bias, 25 repeated measurements were performed on the reference standard. A preliminary investigation did not detect any linearity deviations, so linearity must not be considered.

	Standard 1		Standard 1		Standard 1
Trial 1	53,0110	Trial 11	53,0105	Trial 21	53,0110
Trial 2	53,0110	Trial 12	53,0120	Trial 22	53,0110
Trial 3	53,0115	Trial 13	53,0110	Trial 23	53,0110
Trial 4	53,0110	Trial 14	53,0110	Trial 24	53,0115
Trial 5	53,0105	Trial 15	53,0110	Trial 25	53,0110
Trial 6	53,0105	Trial 16	53,0105	Trial 26	
Trial 7	53,0110	Trial 17	53,0115	Trial 27	
Trial 8	53,0110	Trial 18	53,0110	Trial 28	
Trial 9	53,0110	Trial 19	53,0105	Trial 29	
Trial 10	53,0110	Trial 20	53,0105	Trial 30	

The information about the measuring system and the measured quantity values gained in the experiment lead to the following uncertainty budget and overview of results.

Uncertainty components	Symbol	Type	u	Rank
Resolution of the measuring system	u_{RE}	B	0.000144	5*
Calibration uncertainty	u_{CAL}	B	0.000800	1
Repeatability on reference standard	$u_{EV/R}$	A	0.000367	3
Uncertainty from linearity	u_{LIN}	B		
Uncertainty from Bias	u_{BI}	A	0.000277	4
fmax of dial gauge (MPE)	u_{REST}	B	0.000693	2
Measurement system	u_{MS}		0.00115	

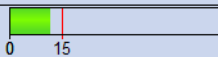
Tolerance	TOL	=	0.0400	
Resolution	%RE	=	1.25%	
Combined standard uncertainty	u_{MS}	=	0.00115	
Expanded measurement uncertainty	U_{MS}	=	0.00231	
Capability ratio limit	Q_{MS_max}	=	15.00%	
Capability ratio	Q_{MS}	=	11.54%	
Minimum tolerance	TOL _{MIN-UMS}	=	0.0308	

Due to a percentage resolution %RE of 1,25% and a capability ratio Q_{MS} of 11,54%, the measuring system capability of the automated measuring equipment is established.

After observing the measuring system, the measurement process of the automated test device is analyzed. In an experiment, 2 repeated measurements are performed on each of 10 test parts.

	Trial 1	Trial 2
1	30,0110	30,0110
2	30,0115	30,0120
3	30,0100	30,0100
4	30,0110	30,0110
5	30,0115	30,0115
6	30,0110	30,0110
7	30,0120	30,0120
8	30,0100	30,0100
9	30,0110	30,0110
10	30,0110	30,0110

In addition to the repeatability on test parts, the temperature influence must also be considered. It is calculated from the difference between the expansion of the working standard and the test part and from the general uncertainty from temperature without correcting the linear expansion.

This leads to the following uncertainty budget and overview of results.

Uncertainty components	Symbol	Type	u	Rank
Resolution of the measuring system	u_{RE}	B	0.000144	7*
Calibration uncertainty	u_{CAL}	B	0.000800	2
Repeatability on reference standard	u_{EVR}	A	0.000367	5
Uncertainty from linearity	u_{LIN}	B		
Uncertainty from Bias	u_{BI}	A	0.000277	6
fmax of dial gauge (MPE)	u_{REST}	B	0.000693	3
Measurement system	u_{MS}		0.00115	
Repeatability on test parts	u_{EVO}	A	0.000112	8*
Temp. uncertainty from set up	u_{TD}	B	0.00176	1
Temperature without correction	u_{TA}	B	0.000519	4
Measurement process	u_{MP}		0.00217	

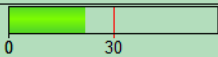
Combined standard uncertainty	u_{MP}	=	0.00217	
Expanded measurement uncertainty	U_{MP}	=	0.00433	
Capability ratio limit	Q_{MP_max}	=	30.00%	
Capability ratio	Q_{MP}	=	21.67%	
Minimum tolerance	$TOL_{MIN-UMP}$	=	0.0289	

Due to a capability ratio Q_{MP} of 21,67% in case of a process capability ratio limit Q_{MP_max} of 30%, the measurement process capability of the automated test device is established.

Annex F.5 Measurement Process Capability of a Multiple-point Measuring Instrument

The measurement process capability for a multiple-point measuring instrument with 3 equal measuring points must be established and documented.

First, the measuring system is observed by considering the influence factors of resolution, calibration uncertainty on standards, repeatability on standards, bias and sensor/touching as additional uncertainty components.

Information about measuring system	
Nominal dimension	64,505 mm
Upper specification limit U	64,530 mm
Lower specification limit L	64,480 mm
Resolution of the measuring system RE (1 digit = 0,0001mm)	0,1 μm
Calibration uncertainty U_{CAL}	1,8 μm
Coverage factor k_{CAL}	2
Linearity u_{LIN} (from preliminary investigation)	0
Error limit of sensor / by touching	0,8 μm
Reference value standard 1/meas. point 1	64,5042 mm
Reference value standard 1/meas. point 2	64,5035 mm
Reference value standard 1/meas. point 3	64,5016 mm
Reference value standard 2/meas. point 1	64,5421 mm
Reference value standard 2/meas. point 2	64,5449 mm
Reference value standard 2/meas. point 3	64,5465 mm
Reference value standard 3/meas. point 1	64,4604 mm
Reference value standard 3/meas. point 2	64,4612 mm
Reference value standard 3/meas. point 3	64,4596 mm
Capability ratio limit of measuring system Q_{MS_max}	15%



Information about measurement process	
Expansion coefficient α of test part for steel	11,5 1/K · 10 ⁻⁶ /K
Expansion coefficient α of measuring system for steel	11,5 1/K · 10 ⁻⁶ /K
Standard uncertainty from expansion coefficients of test part $U_{\alpha OBJ}$ for steel	1,2 1/K · 10 ⁻⁶ /K
Standard uncertainty from expansion coefficients of measuring system $U_{\alpha R}$ for steel	1,2 1/K · 10 ⁻⁶ /K
Maximum temperature (environment)	30° C
Value displayed by measuring system	64,505 mm
error limit from compensation for temperature difference	2,2 μ m
Capability ratio limit measurement process Q_{MP_max}	30%

In order to determine the standard uncertainties from repeatability on standards and from measurement bias, 10 repeated measurements on each of 3 reference standards were performed in an experiment.

	meas. point 1			meas. point 2			meas. point 3		
	Standard 1	Standard 2	Standard 3	Standard 1	Standard 2	Standard 3	Standard 1	Standard 2	Standard 3
Reference value	64,5042	64,5421	64,4604	64,5035	64,5449	64,4612	64,5016	64,5465	64,4596
Trial 1	64,5040	64,5430	64,4608	64,5029	64,5454	64,4616	64,5026	64,5485	64,4617
Trial 2	64,5040	64,5430	64,4607	64,5032	64,5455	64,4617	64,5025	64,5484	64,4616
Trial 3	64,5038	64,5430	64,4607	64,5031	64,5454	64,4614	64,5025	64,5485	64,4615
Trial 4	64,5039	64,5430	64,4608	64,5031	64,5454	64,4617	64,5026	64,5484	64,4616
Trial 5	64,5039	64,5430	64,4609	64,5032	64,5453	64,4613	64,5026	64,5486	64,4615
Trial 6	64,5038	64,5430	64,4608	64,5031	64,5452	64,4613	64,5026	64,5486	64,4617
Trial 7	64,5039	64,5431	64,4608	64,5031	64,5453	64,4616	64,5026	64,5485	64,4618
Trial 8	64,5039	64,5431	64,4608	64,5031	64,5454	64,4616	64,5026	64,5486	64,4618
Trial 9	64,5040	64,5431	64,4610	64,5031	64,5453	64,4619	64,5026	64,5485	64,4618
Trial 10	64,5039	64,5431	64,4609	64,5031	64,5453	64,4616	64,5026	64,5486	64,4619

The information about the measuring system and the measured quantity values gained in the experiment lead to the following uncertainty budget and overview of results.

Uncertainty components	Symbol	Type	u	Rank
Resolution of the measuring system	u_{RE}	B	0.0000289	5*
Calibration uncertainty	u_{CAL}	B	0.000900	2
Repeatability on reference standard	u_{EVR}	A	0.000189	4
Uncertainty from linearity	u_{LIN}	B		
Uncertainty from Bias	u_{BI}	A	0.00121	1
Error limit of sensor / by touching	u_{REST}	B	0.000462	3
Measurement system	u_{MS}		0.00159	

Tolerance	TOL	=	0.0500	
Resolution	%RE	=	0.20%	
Combined standard uncertainty	u_{MS}	=	0.00159	
Expanded measurement uncertainty	U_{MS}	=	0.00317	
Capability ratio limit	Q_{MS_max}	=	15.00%	
Capability ratio	Q_{MS}	=	12.69%	
Minimum tolerance	$TOL_{MIN-U_{MS}}$	=	0.0423	

Due to a percentage resolution %RE of 0,2% and a capability ratio Q_{MS} of 12,69%, the measuring system capability of the multiple-point measuring instrument is established.

Secondly, the entire measurement process is observed. In an experiment, the influence factors of repeatability on standards, reproducibility of places of measurement and of their interactions are determined. Moreover, the temperature influence after the calculation without correcting linear expansion and a residual uncertainty from compensation for temperature difference are considered. In order to calculate the residual uncertainty from compensation for temperature difference, an individual experiment was conducted during a preliminary investigation (measured quantity value plotted on the temperature sequence/cooling curve is constant) and a error limit of 2,2 μm was determined.

In the experiment for the measurement process, 2 repeated measurements were taken at every measuring point on each of 10 test parts. The recorded measured quantity values are evaluated using the method of ANOVA.

	meas. point 1		meas. point 2		meas. point 3	
	Trial 1	Trial 2	Trial 1	Trial 2	Trial 1	Trial 2
1	64,4959	64,4965	64,4955	64,4956	64,4980	64,4980
2	64,4976	64,4978	64,4973	64,4977	64,4992	64,4991
3	64,4957	64,4958	64,4957	64,4957	64,4975	64,4975
4	64,4945	64,4945	64,4942	64,4941	64,4961	64,4960
5	64,4866	64,4868	64,4865	64,4867	64,4886	64,4887
6	64,4994	64,4994	64,4989	64,4989	64,5011	64,5011
7	64,5019	64,5020	64,5005	64,5003	64,5029	64,5028
8	64,4996	64,4995	64,4990	64,4992	64,5012	64,5012
9	64,4974	64,4975	64,4971	64,4970	64,4989	64,4990
10	64,5001	64,5003	64,4998	64,4998	64,5017	64,5017

The information about the measuring system and the measured quantity values gained in the experiment lead to the following uncertainty budget and overview of results.

Uncertainty components	Symbol	Type	u	Rank
Resolution of the measuring system	u_{RE}	B	0.0000289	10*
Calibration uncertainty	u_{CAL}	B	0.000900	5
Repeatability on reference standard	u_{EVR}	A	0.000189	8
Uncertainty from linearity	u_{LIN}	B		
Uncertainty from Bias	u_{BI}	A	0.00121	3
Error limit of sensor / by touching	u_{REST}	B	0.000462	6
Measurement system	u_{MS}		0.00159	
Repeatability on test parts	u_{EVO}	A	0.000121	9*
Reproducibility of the measuring points	u_{GV}	A	0.00107	4
Uncertainty from interactions	u_{IAI}	A	0.000218	7
Uncertainty from temperature	u_T	B	0.00126	2
Error limit of temperature compensation	u_{REST}	B	0.00127	1
Measurement process	u_{MP}		0.00263	

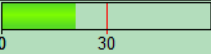
Combined standard uncertainty	u_{MP}	=	0.00263	
Expanded measurement uncertainty	U_{MP}	=	0.00526	
Capability ratio limit	Q_{MP_max}	=	30.00%	
Capability ratio	Q_{MP}	=	21.03%	
Minimum tolerance	$TOL_{MIN-UMP}$	=	0.0351	

Due to a capability ratio Q_{MP} of 21,03% in case of a process capability ratio limit Q_{MP_max} of 30%, the measurement process capability of the multiple-point measuring instrument is established.

Annex F.6 Optimizing a Measurement Process

During an in-process inspection, the diameter of an engine shaft shall be measured. For this purpose, a qualified measuring system must be selected in order to evaluate the entire measurement process. A first review is based on a measuring system composed of a precision snap gauge, a mechanical dial gauge and a working standard.

A general selection and evaluation of the measuring system / measurement process is based on the general data about the respective measurement component (mechanical dial gauge, precision snap gauge, working standard, etc.) rather than on specific individual data.

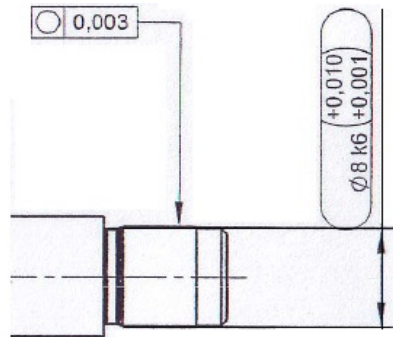

Engine shaft specifications	
Nominal dimension	8 mm
Upper deviation	+0,010 mm
Lower deviation	+0,001 mm
Upper specification limit U	8,010 mm
Lower specification limit L	8,001 mm
Roundness	0,003 mm

Information about mechanical dial gauge	
Resolution of the measuring system RE (1 digit = 0,0005 mm)	0,5 μm
Deviation range f_{total} (MPE)	0,6 μm
Measuring interval	+/- 25 μm

Information about precision snap gauge	
Parallelism (according to specification)	0,6 μm
Measuring force	3-10 N
Adjustment range	0 – 30 mm
Measuring span	2 mm
Measuring surfaces	D 8 mm

Information about working standard	
Reference value of standard	8,0005 mm
Calibration uncertainty U_{CAL}	0,6 μm
Coverage factor k_{CAL}	2
Temperature during calibration	20 °C
Linearity u_{LIN}	0

Before a measuring system can be applied for measurements, it must be set using a standard. The measuring system is set according to the calibrated actual value of the standard (working standard) which makes the system ready for use.

In order to check this procedure, 25 repeated measurements on the standard are performed and the uncertainty from “repeatability” and “measurement bias” is determined.



	Standard 1		Standard 1		Standard 1
Trial 1	8,0005	Trial 11	8,0005	Trial 21	8,0005
Trial 2	8,0005	Trial 12	8,0010	Trial 22	8,0005
Trial 3	8,0005	Trial 13	8,0005	Trial 23	8,0005
Trial 4	8,0005	Trial 14	8,0005	Trial 24	8,0010
Trial 5	8,0005	Trial 15	8,0010	Trial 25	8,0005
Trial 6	8,0005	Trial 16	8,0005	Trial 26	
Trial 7	8,0005	Trial 17	8,0005	Trial 27	
Trial 8	8,0005	Trial 18	8,0005	Trial 28	
Trial 9	8,0005	Trial 19	8,0005	Trial 29	
Trial 10	8,0005	Trial 20	8,0005	Trial 30	

Remark: Even if a measuring system was set using a reference standard, the limits of error of the dial gauge and the deviations of the precision snap gauge must be considered. Although the repeatability and systematic measurement error are known for this working point, they are unknown for measured quantity values lying around this working point. For values around the working point, the manufacturer of the measuring system only guarantees measurement results that do not exceed the specified limits of error (MPE). The same applies to the parallelism of the measuring surfaces and the setting using the standard. In this case, the deviations for the setting point (actual value of the working standard) are known, but they do not apply to lower or higher measured quantity values automatically.

A previous inspection confirmed that the deviations caused by temperature variations are negligible when the system is set once an hour because the materials have similar thermal expansion coefficients.

The specifications, information and measured quantity values lead to the following uncertainty budget and overview of results.

Uncertainty components	Symbol	Type	u	Rank
Resolution of the measuring system	u _{RE}	B	0.000144	4*
Calibration uncertainty	u _{CAL}	B	0.000300	2
Repeatability on reference standard	u _{EVr}	A	0.000166	3
Uncertainty from linearity	u _{LIN}	B		
Uncertainty from Bias	u _{BI}	A	0.0000346	5
Uncertainty from parallelism	u _{REST}	B	0.000346	1
Uncertainty from deviation range	u _{REST}	B	0.000346	1
Measurement system	u _{MS}		0.000599	

Tolerance	TOL	=	0.0090	
Resolution	%RE	=	5.56%	
Combined standard uncertainty	u _{MS}	=	0.000599	
Expanded measurement uncertainty	U _{MS}	=	0.00120	
Capability ratio limit	Q _{MS_max}	=	15.00%	
Capability ratio	Q _{MS}	=	26.62%	
Minimum tolerance	TOL _{MIN-U_{MS}}	=	0.0160	

The overview of results shows that the capability of the measuring system with the mechanical dial gauge is not established due to a low resolution and a capability ratio Q_{MS} of 26,62% that is too high.

Corrective action is taken by replacing the mechanical dial gauge by an incremental gauge with a lower MPE.

Information about incremental gauge	
Resolution of the measuring system RE (1 digit = 0,0001 mm)	0,1 μm
MPE of incremental gauge	0,1 μm
Measuring interval 12 mm	12000 μm



In this case, the measuring system must also be set using a standard at first. The measuring system is set according to the calibrated actual value of the standard (working standard) which makes the system ready for use. In order to check this procedure, 25 repeated measurements on the standard are performed and the uncertainty from “repeatability” and “measurement bias” is determined.

	Standard 1		Standard 1		Standard 1
Trial 1	8,0004	Trial 11	8,0003	Trial 21	8,0003
Trial 2	8,0003	Trial 12	8,0004	Trial 22	8,0004
Trial 3	8,0004	Trial 13	8,0004	Trial 23	8,0004
Trial 4	8,0003	Trial 14	8,0004	Trial 24	8,0004
Trial 5	8,0004	Trial 15	8,0004	Trial 25	8,0003
Trial 6	8,0003	Trial 16	8,0004	Trial 26	
Trial 7	8,0004	Trial 17	8,0004	Trial 27	
Trial 8	8,0004	Trial 18	8,0004	Trial 28	
Trial 9	8,0004	Trial 19	8,0003	Trial 29	
Trial 10	8,0004	Trial 20	8,0004	Trial 30	

The specifications, information and measured quantity values lead to the following uncertainty budget and overview of results for the measuring system with incremental gauge.

Since the resolution is already included as an uncertainty component in the repeated measurements, it is not considered twice.

Uncertainty components	Symbol	Type	u	Rank
Resolution of the measuring system	u_{RE}	B	0.0000289	6*
Calibration uncertainty	u_{CAL}	B	0.000300	2
Repeatability on reference standard	u_{EVR}	A	0.0000458	5
Uncertainty from linearity	u_{LIN}	B		
Uncertainty from Bias	u_{BI}	A	0.0000739	3
Uncertainty from parallelism	u_{REST}	B	0.000346	1
MPE of incremental gauge	u_{REST}	B	0.0000577	4
Measurement system	u_{MS}		0.000470	

Tolerance	TOL	=	0.0090	
Resolution	%RE	=	1.11%	
Combined standard uncertainty	u_{MS}	=	0.000470	
Expanded measurement uncertainty	U_{MS}	=	0.000940	
Capability ratio limit	Q_{MS_max}	=	15.00%	
Capability ratio	Q_{MS}	=	20.89%	
Minimum tolerance	TOL _{MIN-UMS}	=	0.0125	

The inspection of the measuring system with an incremental gauge shows that the resolution is sufficiently high, however, the capability ratio Q_{MS} exceeds the capability ratio limit Q_{MS_max} . As the uncertainty budget shows, capability cannot be established because of the influence of the parallelism of the precision snap gauge and the calibration uncertainty on the working standard.

The next corrective action to be taken is to test a non-contact measuring instrument (laser micrometer). In this case, the measurement result is not affected by the main mechanical influence factor (parallelism of the precision

snap gauge and calibration uncertainty on the working standard). The laser micrometer is calibrated by the manufacturer over the measuring interval and is ready for use immediately after it is switched on. Compared to the previous measuring systems, a laser micrometer need not be set using a working standard for the specified MPE range.

Information about laser micrometer	
Resolution of the measuring system RE (1 digit = 0,0001 mm)	0,1 μm
Linearity deviation	0,2 μm
MPE of laser micrometer (calibrated at 20° C)	0,4 μm
Ambient temperature during the analysis of measured quantity values	26,5° C

In order to establish the measuring system capability of the laser micrometer under real conditions, 25 repeated measurements at the same measuring point of the standard is performed.

	Standard 1		Standard 1		Standard 1
Trial 1	8,0010	Trial 11	8,0011	Trial 21	8,0011
Trial 2	8,0010	Trial 12	8,0010	Trial 22	8,0010
Trial 3	8,0010	Trial 13	8,0011	Trial 23	8,0011
Trial 4	8,0010	Trial 14	8,0010	Trial 24	8,0011
Trial 5	8,0010	Trial 15	8,0010	Trial 25	8,0012
Trial 6	8,0011	Trial 16	8,0011	Trial 26	
Trial 7	8,0010	Trial 17	8,0011	Trial 27	
Trial 8	8,0011	Trial 18	8,0011	Trial 28	
Trial 9	8,0010	Trial 19	8,0011	Trial 29	
Trial 10	8,0010	Trial 20	8,0011	Trial 30	

The measured quantity values and resolution of the measuring system lead to the following uncertainty budget.

Uncertainty components	Symbol	Type	u	Rank
Resolution of the measuring system	u _{RE}	B	0.0000289	4*
Calibration uncertainty	u _{CAL}	B		
Repeatability on reference standard	u _{EV_R}	A	0.0000583	3
Uncertainty from linearity	u _{LIN}	B	0.000115	2
Uncertainty from Bias	u _{BI}	A	0.000321	1
Measurement system	u _{MS}		0.000346	

The uncertainty budget shows a high uncertainty from the measurement bias. This high influence is caused by the fact that all the recorded measured quantity values deviate from the reference quantity value of the standard uniformly because the reference quantity value of the standard was calibrated at 20° C. However, the laser micrometer measured the standard at an ambient temperature of 26,5° C. Due to the temperature variation, the reference standard is subject to linear expansion according to the formula:

$$\Delta l = \Delta T \cdot \alpha \cdot l$$



Expansion coefficient of reference standard:

α (steel) = 11,5 +/-1 in 10⁻⁶ K⁻¹ at 20° C

$\Delta l = 6,5 * 11,5 * 10^{-6} * 8,0005 * = 0,598 \mu m = 0,6 \mu m$.

If the reference quantity value of the standard is reduced by 0,6 μm , the following uncertainty budget and the associated evaluations are obtained.

Uncertainty components	Symbol	Type	u	Rank
Resolution of the measuring system	U _{RE}	B	0.0000289	3*
Calibration uncertainty	U _{CAL}	B		
Repeatability on reference standard	U _{EVR}	A	0.0000583	2
Uncertainty from linearity	U _{LIN}	B	0.000115	1
Uncertainty from Bias	U _{BI}	A	0.0000254	4
Measurement system	U _{MS}		0.000132	

Tolerance	TOL	=	0.0090	
Resolution	%RE	=	1.11%	
Combined standard uncertainty	u _{MS}	=	0.000132	
Expanded measurement uncertainty	U _{MS}	=	0.000264	
Capability ratio limit	Q _{MS_max}	=	15.00%	
Capability ratio	Q _{MS}	=	5.86%	
Minimum tolerance	TOL _{MIN-UMS}	=	0.00352	

Since a MPE is specified for the laser micrometer, the MPE is used for establishing measuring system capability in order to reduce the effort for the experiment. This leads to the following uncertainty budget and the associated evaluation of the measuring system.

Uncertainty components	Symbol	Type	u	Rank
Resolution of the measuring system	U _{RE}	B		
MPE	U _{MPE}	B	0.000231	1
Measurement system	U _{MS}		0.000231	

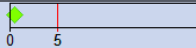
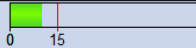
Tolerance	TOL	=	0.0090	
Resolution	%RE	=	1.11%	
Combined standard uncertainty	u _{MS}	=	0.000231	
Expanded measurement uncertainty	U _{MS}	=	0.000462	
Capability ratio limit	Q _{MS_max}	=	15.00%	
Capability ratio	Q _{MS}	=	10.26%	
Minimum tolerance	TOL _{MIN-U_{MS}}	=	0.00616	

The overview of results shows that the measuring system of the laser micrometer meets the demands on the resolution %RE and the capability ratio Q_{MS} . The capability of the measuring system is established. In the next step, the measurement process is observed. In an experiment, 3 operators take 2 repeated measurements on each of 10 engine shafts.

	Operator A		Operator B		Operator C	
	Trial 1	Trial 2	Trial 1	Trial 2	Trial 1	Trial 2
1	8,0063	8,0070	8,0064	8,0071	8,0066	8,0064
2	8,0102	8,0101	8,0102	8,0102	8,0101	8,0100
3	8,0077	8,0078	8,0078	8,0078	8,0077	8,0078
4	8,0086	8,0089	8,0088	8,0087	8,0087	8,0089
5	8,0084	8,0082	8,0082	8,0083	8,0083	8,0083
6	8,0091	8,0090	8,0088	8,0090	8,0090	8,0091
7	8,0084	8,0082	8,0082	8,0083	8,0084	8,0084
8	8,0088	8,0087	8,0086	8,0085	8,0086	8,0086
9	8,0082	8,0077	8,0078	8,0087	8,0087	8,0082
10	8,0081	8,0083	8,0084	8,0082	8,0082	8,0084

This leads to an expanded uncertainty budget for the measurement process.

Uncertainty components	Symbol	Type	u	Rank
Resolution of the measuring system	u_{RE}	B		
MPE	u_{MPE}	B	0.000231	1
Measurement system	u_{MS}		0.000231	
Reproducibility of operators	u_{AV}	A	0.000	3*
Repeatability on test parts	u_{EVO}	A	0.000196	2
Uncertainty from interactions	u_{IAI}	A	[pooling]	
Measurement process	u_{MP}		0.000303	

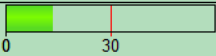
Combined standard uncertainty	u_{MP}	=	0.000303	
Expanded measurement uncertainty	U_{MP}	=	0.000606	
Capability ratio limit	Q_{MP_max}	=	30.00%	
Capability ratio	Q_{MP}	=	13.48%	
Minimum tolerance	$TOL_{MIN-UMP}$	=	0.00404	

Due to a capability ratio Q_{MP} of 13,48% in case of a process capability ratio limit Q_{MP_max} of 30%, a first review of the measurement process (without long-term analysis) establishes capability. The process can be used in production.

In order to prove conformance or non-conformance, the form deviation (roundness) must be considered as a further influence factor affecting the test part. The following example is based on the information from a drawing where the maximum permissible measurement error amounts to 0,003 mm.

Remark: Since a roundness figure always refers to a radius, it must be multiplied by a factor of 2 in order to analyze a diameter.

Uncertainty components	Symbol	Type	u	Rank
Resolution of the measuring system	u_{RE}	B		
MPE	u_{MPE}	B	0.000231	2
Measurement system	u_{MS}		0.000231	
Reproducibility of operators	u_{AV}	A	0.000	4*
Repeatability on test parts	u_{EVO}	A	0.000196	3
Uncertainty from interactions	u_{IAI}	A	[pooling]	
Test part inhomogeneity	u_{OBJ}	B	0.00173	1
Measurement process	u_{MP}		0.00176	

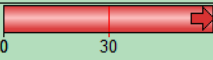
Combined standard uncertainty	u_{MP}	=	0.00176	
Expanded measurement uncertainty	U_{MP}	=	0.00352	
Capability ratio limit	Q_{MP_max}	=	30.00%	
Capability ratio	Q_{MP}	=	78.15%	
Minimum tolerance	$TOL_{MIN-UMP}$	=	0.0234	

The conformity evaluation shows that the permissible roundness results in a capability ratio Q_{MP} exceeding the process capability ratio limit Q_{MP_max} considerably. Thus, the capability of the entire measurement process including the maximum permissible measurement error is not established anymore.

Corrective action can be taken by using a measurement method performing several measurements on the diameter of the engine shaft to be measured, By using laser micrometer, it is possible to record the mean, maximum and minimum value of a measurement e.g. in one revolution or in several measurements on the diameter. This method helps to reduce the uncertainty from form deviations considerably because the maximum and minimum diameters are actually measured. Thus, the customer is guaranteed that both diameters stay within the limits in the context of measurement uncertainty.

The uncertainty from the minimum and maximum diameter of the manual measurement method was determined experimentally and amounts to $R = 0,6 \mu\text{m}$. Since the diameter was only measured at one measuring point, an additional uncertainty should be expected. An actual form deviation with a error limit of $0,9 \mu\text{m}$ is assumed. This leads to the following results.

Uncertainty components	Symbol	Type	u	Rank
Resolution of the measuring system	u_{RE}	B		
MPE	u_{MPE}	B	0.000231	2
Measurement system	u_{MS}		0.000231	
Reproducibility of operators	u_{AV}	A	0.000	4*
Repeatability on test parts	u_{EVO}	A	0.000196	3
Uncertainty from interactions	u_{AI}	A	[pooling]	
Test part inhomogeneity	u_{OBJ}	B	0.000520	1
Measurement process	u_{MP}		0.000602	

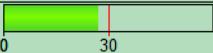
Combined standard uncertainty	u_{MP}	=	0.000602	
Expanded measurement uncertainty	U_{MP}	=	0.00120	
Capability ratio limit	Q_{MP_max}	=	30.00%	
Capability ratio	Q_{MP}	=	26.74%	
Minimum tolerance	$TOL_{MIN-UMP}$	=	0.00802	

Due to a capability ratio Q_{MP} of 26,74% in case of a process capability ratio limit Q_{MP_max} of 30%, the measurement process capability for production (without long-term analysis) is established.

For further optimizing the measurement process, the manual measurement method for determining the form deviation was changed to an automated method. This leads to a error limit of $0,6 \mu\text{m}$ that is associated with the actu-

al form deviation. The stability was observed in a long-term analysis and includes a error limit of $0,35 \mu m$. This leads to the following uncertainty budget and overview of results.

Uncertainty components	Symbol	Type	u	Rank
Resolution of the measuring system	U _{RE}	B		
MPE	U _{MPE}	B	0.000231	2
Measurement system	U _{MS}		0.000231	
Reproducibility of operators	U _{AV}	A	0.000	5*
Repeatability on test parts	U _{EVO}	A	0.000196	4
Uncertainty from interactions	U _{IAI}	A	[pooling]	
Test part inhomogeneity	U _{OBJ}	B	0.000346	1
Reproducibility over time	U _{STAB}	B	0.000202	3
Measurement process	U _{MP}		0.000503	

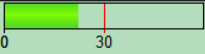
Combined standard uncertainty	U _{MP}	=	0.000503	
Expanded measurement uncertainty	U _{MP}	=	0.00101	
Capability ratio limit	Q _{MP_max}	=	30.00%	
Capability ratio	Q _{MP}	=	22.34%	
Minimum tolerance	TOL _{MIN-UMP}	=	0.00670	

Due to a capability ratio Q_{MP} of 22,34% in case of a process capability ratio limit Q_{MP_max} of 30%, the measurement process capability for production is established.

Annex F.7 Compensation for Temperature Difference

Calculating the standard uncertainty u_T without correction of different linear expansions

The nominal diameter of 85 mm shall be measured on a test part made of aluminium, however, without making any major compensation for temperature difference. A setting ring gauge made of steel is used for a comparison measurement. Temperatures of up to 30°C can occur at the workstation. There are not any precise information about the expansion coefficients of the test part and setting ring gauge available.

Information about temperature influences	
Nominal dimension	85,00 mm
Length of the standard at 20° C (Ø setting ring gauge) y_R	85,002 mm
Maximum temperature t_{MAX}	30° C
Expansion coefficient of test part α_{OBJ}	0,000024 1/K
Expansion coefficient of standard α_R	0,0000115 1/K
Standard uncertainty from thermal expansion coefficient of test part $u_{\alpha_{OBJ}}$	10% of α_{OBJ}
Standard uncertainty from thermal expansion coefficient of standard u_{α_R}	10% of α_R

According to these specifications, the measurement error is calculated by the formula B.6

$$\Delta y = 85,002 \cdot (30 - 20) \cdot (0,000024 - 0,0000115) = 0,0106 \text{ mm}.$$

Because of uncertain expansion coefficients, the uncertainty from other influence components in case of a temperature deviation of 10° C from the reference temperature of 10° C is calculated by formula B.5.

$$\begin{aligned} u_{REST} &= 85,002 \cdot \sqrt{10^2 \cdot 0,00000115^2 + 10^2 \cdot 0,0000024^2} \\ &= 0,0023 \text{ mm}. \end{aligned}$$

According to formula B.7, these results lead to the error limit of

$$a = |0,0106| + 2 \cdot 0,0023 = 0,0152 \text{ mm}$$

and, according to formula B.8, to a standard uncertainty from temperature of

$$u_T = \frac{0,0152}{\sqrt{3}} = 0,0088 \text{ mm}.$$

In this case (assuming that $u_{\alpha_{OBJ;R}} = 0,1 \cdot \alpha_{OBJ;R}$), the standard uncertainty can also be determined with the help of Table B.2. Using the value $u_T = 10,3 \mu\text{m}$ per 100 mm from the table, the following result is obtained (aside from little rounding differences):

$$u_T = 10,3 \cdot \frac{85,002}{100} = 8,76 \mu\text{m}.$$

Calculating the standard uncertainty u_T with correction of different linear expansions

The uncertainty budget shows that the uncertainty component displayed above is too high. Therefore, the measurement results are corrected in order to reduce the uncertainty components to an acceptable level. In order to record the temperatures occurring during the measurement, a temperature measuring device is used that, according to manufacturer specifications, does not exceed a maximum deviation of $\pm 0,5^\circ\text{C}$.

In case of the test part temperature of $28,2^\circ\text{C}$ and the setting ring gauge temperature of $26,7^\circ\text{C}$, a difference of $d = +0,014 \text{ mm}$ was measured. This leads to a measured quantity value of $\varnothing 85,016 \text{ mm}$. This measured value is corrected according to formula B.3.

$$y_{korr} = \frac{85,002 \cdot (1 + 0,0000115 \cdot (26,7 - 20)) + 0,014}{1 + 0,000024 \cdot (28,2 - 20)} = 85,0058 \text{ mm}.$$

Since the standard uncertainty from the temperature measurement amounts to $u_{\Delta T_{OBJ;R}} = 0,5/\sqrt{3} = 0,2887$, a residual uncertainty remains according to B.5 that represents the standard uncertainty from temperature that is now considerably smaller.

$$u_T = 85,002 \cdot \sqrt{6,7^2 \cdot 0,00000115^2 + 8,2^2 \cdot 0,0000024^2 + 0,0000115^2 \cdot 0,2887^2 + 0,000024^2 \cdot 0,2887^2}$$

$$= 0,0019 \text{ mm.}$$

Conclusion: The advantage of avoiding complicated temperature measurements and compensations in case of high maximum temperatures is always gained on account of a relatively high (often too high) uncertainty component caused by temperature influences. For this reason, in most cases, the more time-consuming method is required, i.e. the temperatures occurring during the measurement must be determined and taken into account. Where possible, the application of modern, computer-based measuring instruments should be considered in test planning. These instruments perform and make most of the measurements and calculations that the users otherwise have to do themselves.

Annex F.8 Inspection by Attribute without Critical Values

A procedure for the visual inspection of semi-finished surfaces on die casting components requires that the capability of the measurement process is established and documented. 2 operators perform 3 repeated measurements on each of 40 semi-finished surfaces. The results of both operators are plotted on a matrix and compared. Then they are checked for symmetry using the Bowker test. The 95% quantile of the χ^2 distribution with 3 degrees of freedom is used as a critical value.

The test results are displayed in the matrix below. Their evaluation is shown in the overview of results.

No. of repetitions		Operator B			
		Result	Result	Result	
Operator A	Result	---	mixed	---	
	---	2	1	0	3
	Result	3	12	2	17
	mixed	7	6	7	20
	---	12	19	9	40

Operator A vs. Operator B			
H ₀	Both operators get comparable results		
H ₁	Both operators get different results		
Test level	critical values		Test statistics
	lower	upper	
$\alpha = 5 \%$	---	7.81	10.0000*
$\alpha = 1 \%$	---	11.34	
$\alpha = 0.1 \%$	---	16.27	
Test results	Null hypothesis rejected at level $\alpha \leq 5\%$		

Thus, the test result exceeds the critical value of the 95% level of confidence, i.e. there is no symmetrical relation between the test results of the two operators. The procedure of the visual inspection is not suitable for semi-finished surfaces.

In order to improve the visual inspection, a new catalogue of boundary samples is introduced and both operators repeat the entire test. This leads to the following matrix and overview of results.

No. of repetitions		Operator B			
		Result	Result	Result	
		---	mixed	***	
Operator A	Result	8	3	1	12

	Result	2	9	3	14
	mixed				
	Result	0	1	13	14

		10	13	17	40

Operator A vs. Operator B			
H ₀	Both operators get comparable results		
H ₁	Both operators get different results		
Test level	critical values		Test statistics
	lower	upper	
α = 5 %	---	7.81	2.20000
α = 1 %	---	11.34	
α = 0.1 %	---	16.27	
Test results	Null hypothesis not rejected		

$\chi^2 = 2,20$ does not exceed the critical value of 7,81. A symmetrical relation between the test results of the two operators is proved. The capability of the visual inspection including a new catalogue of boundary samples is established.

Annex F.9 Inspection by Attribute with Reference Values

The measurement process capability should be established and documented for a measurement procedure with one characteristic that can only be measured by using gauges.

Information about attribute measurement process	
Nominal value	3,600 mm
Upper specification limit U	3,638 mm
Lower specification limit L	3,562mm
Measurement process capability ratio limit Q_{ATTR_max}	30%

The information above specifies the characteristic. Two operators shall perform 2 repeated measurements on each of 20 reference parts. These inspections provide the following unsorted and sorted test results.

n	Ref. 1	X _{A,1}	X _{A,2}	X _{B,1}	X _{B,2}	
1	3,555	☐	☐	☐	☐	😊
2	3,603	+	+	+	+	😊
3	3,571	☐	+	+	+	😡
4	3,594	+	+	+	+	😊
5	3,583	+	+	+	+	😊
6	3,557	☐	+	+	+	😡
7	3,651	+	☐	☐	☐	😡
8	3,629	☐	+	+	+	😡
9	3,642	+	☐	+	+	😡
10	3,663	☐	☐	☐	☐	😞
11	3,634	+	+	+	☐	😡
12	3,638	+	☐	☐	+	😡
13	3,607	+	+	+	+	😊
14	3,612	+	+	+	+	😊
15	3,621	+	+	+	+	😊
16	3,680	☐	☐	☐	☐	😊
17	3,559	☐	☐	☐	+	😡
18	3,571	+	☐	☐	☐	😡
19	3,575	+	☐	☐	+	😡
20	3,547	☐	☐	☐	☐	😊

Unsorted test results

n	Ref. 1	X _{A,1}	X _{A,2}	X _{B,1}	X _{B,2}	
16	3,680	☐	☐	☐	☐	😊
10	3,663	☐	☐	☐	☐	😊
7	3,651	+	☐	☐	☐	😡
9	3,642	+	☐	+	+	😡
12	3,638	+	☐	☐	+	😡
11	3,634	+	+	+	☐	😡
8	3,629	☐	+	+	+	😡
15	3,621	+	+	+	+	😊
14	3,612	+	+	+	+	😊
13	3,607	+	+	+	+	😊
2	3,603	+	+	+	+	😊
4	3,594	+	+	+	+	😊
5	3,583	+	+	+	+	😊
19	3,575	+	☐	☐	+	😡
18	3,571	+	☐	☐	☐	😡
3	3,571	☐	+	+	+	😡
17	3,559	☐	☐	☐	+	😡
6	3,557	☐	+	+	+	😡
1	3,555	☐	☐	☐	☐	😊
20	3,547	☐	☐	☐	☐	😊

Sorted test results

The following statistical values are calculated from the test results.

Last test with agreement on negative result 3,663
 First test with agreement on positive result 3,621
 Last test with agreement on positive result 3,583
 First test with agreement on negative result 3,555

Ranges of the upper and lower conformance zones

$$d_U = 3,663 - 3,621 = 0,042$$

$$d_L = 3,583 - 3,555 = 0,028$$

Average range

$$d = (d_U + d_L) / 2 = (0,042 + 0,028) / 2 = 0,035$$

Uncertainty range and capability ratio

$$U_{ATTR} = d / 2 = 0,035 / 2 = 0,0175$$

$$Q_{ATTR} = 2 U_{ATTR} / TOL \cdot 100\% = 2 \cdot 0,0175 / 0,076 \cdot 100\% = 46,05 \%$$

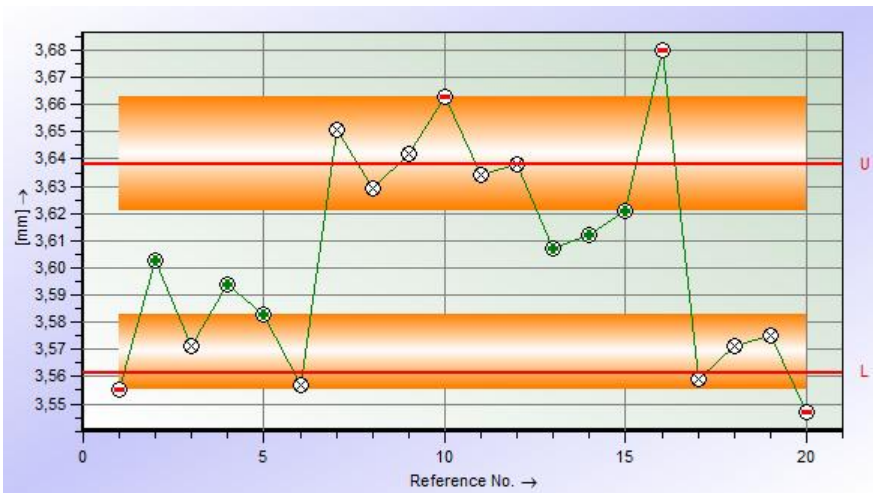

Due to a capability ratio Q_{ATTR} of 46,05% in case of a capability ratio limit Q_{ATTR_max} of 30%, the capability of the measurement procedure using reference values is not established.

11 Index of Formula Symbols

Symbol	Term
MPE	maximum permissible measurement error
U_{AV}	standard uncertainty from reproducibility of operator
U_{BI}	standard uncertainty from measurement bias
U_{CAL}	calibration standard uncertainty on a standard
U_{EV}	standard uncertainty from maximum value of repeatability or resolution measuring system: $\max \{U_{EVR}, U_{RE}\}$ measurement process: $\max \{U_{EVR}, U_{EVO}, U_{RE}\}$
U_{EVO}	standard uncertainty from repeatability on test parts
U_{EVR}	standard uncertainty from repeatability on standards
U_{GV}	standard uncertainty from reproducibility of measuring system
U_{IAI}	standard uncertainty from interactions
U_{LIN}	standard uncertainty from linearity
U_{MP}	combined standard uncertainty on measurement process
U_{MS}	combined standard uncertainty on measuring system
U_{MS_REST}	standard uncertainty from other influence components not included in the measuring system analysis
U_{OBJ}	standard uncertainty from test part inhomogeneity
U_{RE}	standard uncertainty from resolution of measuring system
U_{REST}	standard uncertainty from other influence components not included in the analysis of the measurement process
U_{STAB}	standard uncertainty from stability of measuring system
U_T	standard uncertainty from temperature
$u(x_i)$	standard uncertainty
$u(y)$	combined standard uncertainty
U_{ATTR}	uncertainty range

Symbol	Term
U_{MP}	expanded measurement uncertainty (measurement process)
U_{MS}	expanded measurement uncertainty (measuring system)
RE	resolution
Bi	bias
Q_{MS}	capability ratio (measuring system)
Q_{MP}	capability ratio (measurement process)
Q_{MS_max}	capability ratio limit (measuring system)
Q_{MP_max}	capability ratio limit (measurement process)
TOL	tolerance
$TOL_{MIN-UMP}$	minimum permissible tolerance of measurement process
$TOL_{MIN-UMS}$	minimum permissible tolerance of measuring system
k	coverage factor
a	variation limit
b	distribution factor
$U^{1)}$	upper specification limit U (specification limit that defines the upper limiting value)
$L^{1)}$	lower specification limit L (specification limit that defines the lower limiting value)
P	test result, characteristic value

¹⁾ The GUM [22] or ISO 14253 [13] uses the formula symbol U for the expanded measurement uncertainty. However, new standards, such as ISO 3534-2 [9] refer to the upper specification limit as U . In order to avoid confusions in this document, the expanded measurement uncertainty is referred to as U_{MS} where the measuring system is concerned and U_{MP} when it is about the measurement process.

Symbol	Term
UCL	upper control limit
LCL	lower control limit
C_g	capability index of measuring system
C_{gk}	minimum capability index of measuring system
$C_{p,real}$	real process capability index
s_g	standard deviation
x_m	reference quantity value of the standard
x_{mu}	reference quantity value of the standard at the upper specification limit
x_{mm}	reference quantity value of the standard in the centre of the specification
x_{ml}	reference quantity value of the standard at the lower specification limit
$C_{p,obs}$	observed process capability index
T	temperature
ΔT_{OBJ}	temperature deviation of test part from 20° C
ΔT_R	temperature deviation of scale or standard from 20° C
α_{OBJ}	thermal expansion coefficient of test part
α_R	thermal expansion coefficient of scale or standard
y_R	length of standard at a reference temperature of 20° C
y_{corr}	corrected measured quantity value
d	temperature difference between test part and standard
y_i	measured quantity value
Y	measurement result (measured quantity value y_i including the expanded measurement uncertainty U_{MP})

Symbol	Term
N	number of standards ($n = 1, \dots, N$)
K	number of repeated measurements ($k = 1, \dots, K$) per standard
KB	class width
σ^2	variance
x_n	conventional true value for the n-th standard
y_n	measured quantity value of the n-th standard
y_{nk}	k-th of K measurements on the n-th of N standards
\bar{x}	arithmetic mean of all conventional true values
\bar{y}	arithmetic mean of all measured quantity values
ε_{nk}	deviation of the measured quantity value of the k-th of K measurements on the nth of N standards from its expected value
e_{nk}	residuals of the k-th of K measurements on the n-th of N standards
β_0	y-intercept
$\hat{\beta}_0$	estimated y-intercept
β_1	slope of the regression function
$\hat{\beta}_1$	estimated slope of the regression function
$1-\alpha$	level of confidence
$Z_{1-\alpha/2}$	quantile of standard normal distribution
f	number of degrees of freedom
$t_{f,1-\alpha/2}$	quantile of Student t-distribution with f degrees of freedom
SS	sum of squares
MS	mean square

12 Bibliography

- [1] **A.I.A.G. – Chrysler Corp., Ford Motor Co., General Motors Corp.**
Measurement Systems Analysis, Reference Manual, 4th edition.
Michigan, USA, 2010.
- [2] **Deutscher Kalibrierdienst**
DKD-3: Angabe der Messunsicherheit bei Kalibrierungen.
DKD bei der PTB, Braunschweig, 2002.
- [3] **Deutscher Kalibrierdienst**
DKD-4: Rückführung von Mess- und Prüfmitteln auf nationale Normale.
DKD bei der PTB, Braunschweig, 1998.
- [4] **Dietrich, E. / Schulze, A.**
Measurement Process Qualification: Gage Acceptance and Measurement Uncertainty According to Current Standards, 3th completely revised edition.
Carl Hanser Verlag, Munich, 2011.
- [5] **DIN - Deutsches Institut für Normung**
DIN 1319-1: Grundlagen der Messtechnik – Teil 1: Grundbegriffe.
Beuth Verlag, Berlin, 1995.
- [6] **DIN - Deutsches Institut für Normung**
DIN 1319-2: Grundlagen der Messtechnik – Teil 2: Begriffe für die Anwendung von Messgeräten.
Beuth Verlag, Berlin, 1996.
- [7] **DIN - Deutsches Institut für Normung**
DIN 1319-3: Grundlagen der Messtechnik – Teil 3: Auswertung von Messungen einer einzelnen Messgröße, Messunsicherheit.
Beuth Verlag, Berlin, 1996.

- [8] **DIN - Deutsches Institut für Normung**
DIN 55319-3: Statistische Verfahren - Teil 3: Qualitätsfähigkeitskenngrößen zur Beurteilung von Messprozessen bei multivariat normalverteilten Messergebnissen.
Beuth Verlag, Berlin, 2007.
- [9] **DIN - Deutsches Institut für Normung**
ISO 3534-1 to 3534-3: Statistics – Vocabulary and symbols.
Beuth Verlag, Berlin, 2006.
- [10] **DIN - Deutsches Institut für Normung**
ISO 9000:2005: Quality management systems – Fundamentals and Vocabulary. Beuth Verlag, Berlin, 2005.
- [11] **DIN - Deutsches Institut für Normung**
DIN EN ISO 9001:2008: Qualitätsmanagementsysteme - Anforderungen. Beuth Verlag, Berlin, 2008.
- [12] **DIN - Deutsches Institut für Normung**
EN ISO 10012:2003
Measurement management systems – Requirements for measurement processes and measuring equipment. Beuth Verlag, Berlin, 2004.
- [13] **DIN - Deutsches Institut für Normung**
ISO/TS 14253-1: Geometrical product specifications (GPS). Inspection by measurement of workpieces and measuring equipment. Part 1: Decision rules for proving conformance or non-conformance with specifications.
Beuth Verlag, Berlin, 1999.
- [14] **DIN - Deutsches Institut für Normung**
Supplementary sheet to ISO/TS 14253-1: Inspection by measurement of workpieces and measuring equipment. Guide to the estimation of uncertainty in GPS measurement, in calibration of measuring equipment and in production verification.
Beuth Verlag, Berlin, 1999.

- [15] **DIN - Deutsches Institut für Normung**
ISO/TR 14253-2: Geometrical product specifications (GPS) – Inspection by measurement of workpieces and measuring equipment. Part 2: Guide to the estimation of uncertainty in GPS measurement, in calibration of measuring equipment and in product verification. International Organization for Standardization, Geneva, 1998.
- [16] **DIN - Deutsches Institut für Normung**
ISO/TS 15530-3:2009-07 Geometrical Product Specifications (GPS) – Coordinate measuring machines (CMM): Techniques for evaluation of the uncertainty of measurement - Part 3: Use of calibrated workpieces.
Beuth Verlag, Berlin, 2000.
- [17] **DIN - Deutsches Institut für Normung**
EN ISO/IEC 17000:2004
Conformity assessment – Vocabulary and general principles
Beuth Verlag, Berlin, 2005.
- [18] **DIN - Deutsches Institut für Normung**
EN ISO/IEC 17024:2003
Conformity assessment - General requirements for bodies operating certification of persons
Beuth Verlag, Berlin, 2003.
- [19] **DIN - Deutsches Institut für Normung**
EN ISO/IEC 17025:2005
General requirements for the competence of testing and calibration laboratories
Beuth Verlag, Berlin, 2005.

- [20] **DIN - Deutsches Institut für Normung**
DIN ISO 55350-12: Ausgabe: 1989-03
Begriffe der Qualitätssicherung und Statistik; Merkmalsbezogene Begriffe.
Beuth Verlag, Berlin, 1989.
- [21] **DIN - Deutsches Institut für Normung**
DIN ISO/IEC Guide 99:2007
International vocabulary of metrology (VIM).
Beuth Verlag, Berlin, 2010.
- [22] **DIN - Deutsches Institut für Normung**
ISO/IEC Guide 98-3 (2008): Guide to the expression of uncertainty in measurement (GUM:1995).
International Organization for Standardization, Geneva, 2008.
- [23] **DIN - Deutsches Institut für Normung**
ISO/TS 16949:2009-06 Vornorm: Qualitätsmanagementsysteme -
Besondere Anforderungen bei Anwendungen von ISO 9001:2008
für die Serien- und Ersatzteil-Produktion in der Automobilindustrie.
Beuth Verlag, Berlin, 2009.
- [24] **ISO – International Standard Organization**
ISO/WD 22514-7: Capability and performance – Part 7: Capability
of Measurement Processes.
Geneva, 2008.
- [25] **Q-DAS® GmbH**
Leitfaden der Automobilindustrie zum „Fähigkeitsnachweis von
Messsystemen“, Version 2.1.
Weinheim, 2002.

- [26] **VDA – Verband der Automobilindustrie**
VDA Band 6: Teil 1 - QM - Systemaudit - Grundlage
DIN EN ISO 9001 und DIN EN ISO 9004-1.
VDA, Frankfurt, 2003.
- [27] **VDI/VDE/DGQ Richtlinie**
VDI/VDE/DGQ 2617, Blatt 7: Genauigkeit von Koordinatenmessgeräten - Kenngrößen und deren Prüfung - Ermittlung der Unsicherheit von Messungen auf Koordinatenmessgeräten durch Simulation.
Beuth Verlag, Berlin, 2008.
- [28] **VDI/VDE/DGQ Richtlinie**
VDI/VDE/DGQ 2618, Blatt 9.1: Prüfmittelüberwachung - Prüfanweisung für Messschieber für Außen-, Innen- und Tiefenmaße.
Beuth Verlag, Berlin, 2006.

13 Index

A

absolute measurement · 99
action limits · 71, 78
adjustment · 18
ANOVA · 16
ANOVA tables · 94
ARM · 35
attribute · 85
averaging · 105

B

bias · 16, 50
bibliography · 158

C

calibration · 18
calibration uncertainty · 50, 52, 74
capability · 26, 43, 46
capability analysis · 49, 64
capability of measuring system · 56
capability of the measuring system ·
20
capability of the measuring system ·
29
capability ratios · 40, 68
characteristic · 16
classification · 81
CMM · 117
combined measurement uncertainty ·
38
comparison measurement · 99
conformance zone · 23
conformity · 15
conformity assessment · 15, 29
control chart · 22, 71
control limit · 72
conventional true value · 17
correction · 60, 99, 102

coverage factor · 14, 37
coverage probability · 55
C-value · 47

D

definitions · 13
D-optimum design · 35
D-optimum experimental design · 114

E

environment · 27, 48
evaluation method · 28
expanded · 68
expanded measurement uncertainty ·
15, 29, 37, 38

F

form deviation · 78
formula symbols · 154

G

guidelines · 10
GUM · 10, 13

I

influences · 26, 75
inspection by attribute · 151
inspection by attributes
gauging · 17
inspection by variables
measuring · 17
instrumental drift · 31
interactions · 69, 112

intermediate measurement precision
· 16
intermediate precision · 16

K

k factors · 107

L

lack-of-fit · 61, 62
error limit · 37
limits · 42
linear expansion · 99
linearity · 53
linearity analysis · 60
linearity deviation · 50, 52, 76
long-term analysis · 32

M

man · 28
material measures · 48, 58, 59
maximum permissible measurement
error · 20
measured quantity value · 16
measurement error
systematic · 30, 50, 52, 53, 75
measurement method · 28
measurement procedure · 28
measurement process · 20, 49, 64
measurement process capability · 20,
29
measurement process models · 79
measurement repeatability · 16, 50
measurement result · 16
measurement software · 82
measurement stability · 48, 71
measurement standard · 17, 27
measurement uncertainty · 11, 13
measuring equipment · 19, 27, 48
measuring instrument · 19
measuring system · 19, 27, 50

method of moments · 35
metrological traceability · 18
minimum tolerance · 44, 68
mounting device · 28
MPE · 43
MSA · 16

N

non-conformance zone · 24
not capable · 47

O

observed process capability index · 46
ongoing review · 29, 71, 92
operator · 15, 28, 48, 65, 68
operator influence · 76
outlier · 31, 62

P

place of measurement · 65, 77
pooling · 69, 97

R

random measurement errors · 30
reference quantity values · 86, 88
reference standard · 13, 27
reference temperature · 100
reference values · 149, 151
regression function · 50, 60, 72, 93
regression line · 60
repeatability · 16, 52, 53, 75
repeated measurements · 52, 54, 60
reproducibility · 32, 76
residual · 63
residual standard deviation · 60, 61
residuals · 93
resolution · 19, 50, 52, 53, 74

S

setting · 19
setting a working point · 108
small geometric elements · 81
small tolerances · 81
special measurement processes · 81
stability · 20, 48
stability of the measuring instrument ·
20
standard · 52
standard measurement uncertainty ·
14
 combined · 14
standard normal distribution · 63
standard uncertainty · 14
 combined · 14
standards · 10

T

temperature · 48, 78
temperature influences · 98
test characteristic · 15
test part · 28, 65, 78
test parts · 48
testing · 15
thermal expansion coefficient · 99
time · 65, 78
tolerance · 21

true value · 17
Type 1 study · 54, 56, 75
Type 2 study · 65, 76
Type 3 study · 77
Type A evaluation · 34
 ANOVA · 34
 standard deviation · 34
Type B evaluation · 33, 36

U

uncertainty budget · 14, 45
uncertainty component · 14
uncertainty components · 65
uncertainty range · 25, 85, 88

V

validation · 21, 82
value of the characteristic · 16
verification · 21
vibrations · 48
VIM · 13

W

working standard · 17

14 Downloads

Since some graphics are reduced in size due to the format of this document, they are available for free download. Please use the following access data in order to download a PDF file of the graphics (that are listed below).

Access data:

www.vdaqmc.de/downloads

user name: vda5ppeignung2a

password: 2010vda52

Chap. 3.2 - Fig. 1 - Page 22	Annex F.1 - Figure - Page 113
Chap. 4.1 - Fig. 5 - Page 26	Annex F.2 - Figure - Page 116
Chap. 4.7 - Fig. 7 - Page 41	Annex F.4 - Figure - Page 125
Chap. 4.10 - Fig. 9 - Page 46	Annex F.5 - Figure - Page 127
Chap. 5.2 - Fig. 10 - Page 51	Annex F.5 - Figure - Page 129
Chap. 5.2.2.2 - Fig. 15 - Page 62	Annex F.5 - Figure - Page 130
Chap. 5.2.2.2 - Fig. 16 - Page 63	Annex F.6 - Figure - Page 134
Chap. 5.3 - Fig. 19 - Page 66	Annex F.6 - Figure - Page 136
Cha. 9.3.1 - Fig. 23 - Page 91	Annex F.6 - Figure - Page 138
Annex B - Fig. 24 - Page 98	Annex F.6 - Figure - Page 141
Annex E - Figure - Page 108	Annex F.8 - Figure - Page 149
Annex E - Figure - Page 109	Annex F.8 - Figure - Page 150
Annex E - Figure - Page 109	Annex F.9 - Figure - Page 151
Annex F.1 - Figure - Page 111	Annex F.9 - Figure - Page 152
Annex F.1 - Figure - Page 112	Annex F.9 - Figure - Page 153

Quality Management in the Automotive Industry

The current versions of the published VDA volumes about the quality management in the automotive industry (QAI) are found online under <http://www.vda-qmc.de/en/>.

Our publications can be ordered from our website directly.

Reference:

**Verband der Automobilindustrie e.V. (VDA)
Qualitäts Management Center (QMC)
Behrenstraße 35, 10117 Berlin,
Germany**

Telephone +49 (0) 30 897842 - 235, Telefax +49 (0) 30 897842 - 605
E-Mail: info@vda-qmc.de, Internet: www.vda-qmc.de

Forms:

**Henrich Druck + Medien GmbH
Schwanheimer Straße 110, 60528 Frankfurt am Main
Germany**

Telephone +49 (0) 69 9 67 777-158, Telefax +49 (0) 69 67 77-111
E-Mail: dschwarz@henrich.de, Internet: www.henrich.de

